



KIESELMANN

FLUID PROCESS GROUP

Translation of the original

Operating Instructions

Angle tube strainer

Type 7027

DN25 - DN150

with Slotted strainer insert

Welding end S - S

Threaded connection G - G

Union connection K/M - G



KIESELMANN GmbH

Paul-Kieselmann-Str. 4-10
D - 75438 Knittlingen

 +49(0) 7043 371-0 •  +49(0) 7043 371-125
www.kieselmann.de • info@kieselmann.de

Copyright: © KIESELMANN FLUID PROCESS GROUP

Table of Contents

| | | |
|----------|---|-----------|
| 1 | General informations | 4 |
| 1.1 | Informations for your safety | 4 |
| 1.2 | Marking of security instructions | 4 |
| 1.3 | General designated use | 4 |
| 1.4 | Personnel | 4 |
| 1.5 | Modifications, spare parts, accessories | 5 |
| 1.6 | General instructions | 5 |
| 2 | Safety instructions | 6 |
| 2.1 | Intended use | 6 |
| 2.2 | General notes | 6 |
| 2.3 | General safety instructions | 6 |
| 3 | Function and operation | 7 |
| 3.1 | Description of function | 7 |
| 3.2 | Installation Instructions | 7 |
| 3.3 | General welding guidelines | 7 |
| 3.4 | Cleaning | 7 |
| 4 | Technical data | 8 |
| 5 | Disassembly and assembly | 9 |
| 5.1 | Disassembly | 9 |
| 5.2 | Assembly | 9 |
| 6 | Drawings and dimensions | 10 |
| 6.1 | Drawings | 10 |
| 6.2 | Dimensions | 10 |
| 7 | Wearing parts | 12 |
| 7.1 | Wearing parts list | 12 |

1 General informations

1.1 Informations for your safety

We are pleased that you have decided for a high-class KIESELMANN product. With correct application and adequate maintenance, our products provide long time and reliable operation.





Before installation and initiation, please carefully read this instruction manual and the security advices contained in it. This guarantees reliable and safe operation of this product and your plant respectively. Please note that an incorrect application of the process components may lead to great material damages and personal injury.

In case of damages caused by non observance of this instruction manual, incorrect initiation, handling or external interference, guarantee and warranty will lapse!

Our products are produced, mounted and tested with high diligence. However, if there is still a reason for complaint, we will naturally try to give you entire satisfaction within the scope of our warranty. We will be at your disposal also after expiration of the warranty. In addition, you will also find all necessary instructions and spare part data for maintenance in this instruction manual. If you don't want to carry out the maintenance by yourself, our KIESELMANN - service team will naturally be at your disposal.

1.2 Marking of security instructions

Hints are available in the chapter "safety instructions" or directly before the respective operation instruction. The hints are highlighted with a danger symbol and a signal word. Texts beside these symbols have to be read and adhered to by all means. Please continue with the text and with the handling at the valve only afterwards.

| Symbol | Signal word | Meaning |
|---|-------------|---|
|  | DANGER | Imminent danger which will result severe personal injury or death. |
|  | WARNING | Imminent danger which may result severe personal injury or death. |
|  | CAUTION | Dangerous situation which may cause slight personal injury or material damages. |
|  | NOTICE | An harmful situation which may result in damages of the product itself or of adjacent vicinity. |
|  | INFORMATION | Marks application hints and other information which is particularly useful. |

1.3 General designated use

The fitting is designed exclusively for the purposes described below. Using the fitting for purposes other than those mentioned is considered contrary to its designated use. KIESELMANN cannot be held liable for any damage resulting from such use. The risk of such misuse lies entirely with the user. The prerequisite for the reliable and safe operation of the fitting is proper transportation and storage as well as competent installation and assembly. Operating the fitting within the limits of its designated use also involves observing the operating, inspection and maintenance instructions.

1.4 Personnel

Personnel entrusted with the operation and maintenance of the tank safety system must have the suitable qualification to carry out their tasks. They must be informed about possible dangers and must understand and observe the safety instructions given in the relevant manual. Only allow qualified personnel to make electrical connections.

1.5 Modifications, spare parts, accessories

Unauthorized modifications, additions or conversions which affect the safety of the fitting are not permitted. Safety devices must not be bypassed, removed or made inactive. Only use original spare parts and accessories recommended by the manufacturer.

1.6 General instructions

The user is obliged to operate the fitting only when it is in good working order. In addition to the instructions given in the operating manual, please observe the relevant accident prevention regulations, generally accepted safety regulations, regulations effective in the country of installation, working and safety instructions effective in the user's plant.

2 Safety instructions

2.1 Intended use

The elbow tube strainer is used to filter solid matter in liquids in the food and drinks industry.

2.2 General notes



NOTICE - observe the operating instructions

To avoid danger and damage, the fitting must be used in accordance with the safety instructions and technical data contained in the operating instructions.



NOTICE

All data are in line with the current state of development. Subject to change as a result of technical progress.

2.3 General safety instructions



⚠ WARNING

Risk of injury by outflowing medium

Dismantling the valve or valve assemblies from the plant can cause injuries.

- Medias flowing through the leakage drain outlet are to be drained off without splashing into a discharge arrangement.
- Carry the disassembling only if when the plant has been rendered pressure-less and free of liquid and gas.



⚠ CAUTION

Steps should be taken to ensure that no external forces are exerted on the fitting.

3 Function and operation

3.1 Description of function

The elbow tube strainer is used to filter solid matter in liquids. When the liquid flows through the strainer in the direction of the arrow (see figure), the solid matter is retained in the mesh bottom.

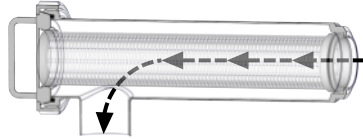

3.2 Installation Instructions

Fitting position

- The installation position is without importance.



CAUTION

Steps should be taken to ensure that no external forces are exerted on the fitting.

3.3 General welding guidelines

Sealing elements integrated in weld components must generally be removed prior to welding. To prevent damage, welding should be undertaken by certified personnel (EN ISO 9606-1). Use the TIG (Tungsten Inert Gas) welding process.



CAUTION

Damage and injuries due to high temperature supply

To avoid a distortion of the components, all welding parts must be welded to stress-relieved. Allow all components to cool before assembling.



NOTICE

Damage due to impurities

Impurities can cause damage to the seals and seals area. Clean inside areas prior to assembly.

3.4 Cleaning

The mesh bottom can be removed from the casing for cleaning.



NOTICE

It is also possible to clean mesh bottoms, which do not have fine wire-cloth screen, by simply rinsing out the strainer in the opposite flow direction.

4 Technical data

| | | |
|---------------------------------------|--|---|
| Model | Angle tube strainer with slotted strainer insert | |
| | <ul style="list-style-type: none"> • Screening direction from inside to outside • Screening direction from outside to inside | |
| | Size | DN25 - DN150 |
| | Connection type | Male part DIN11851 Weld-on end DIN EN 10357 Liner / nut DIN 11851 |
| Temperature range | Operating temperature: | +0°C to +100°C |
| | (depends on medium) | |
| | Sterilisation temperature: | EPDM +120 °C |
| | (SIP 30 min) | HNBR +100 °C NBR +100 °C FKM +100 °C |
| Nominal pressure | DN25 - DN65 | PN 16 |
| | DN80 - DN100 | PN 10 |
| | DN125 - DN 150 | PN 8 |
| Material (in contact with product) | Stainless steel: | <ul style="list-style-type: none"> • 1.4301 / AISI 304 • 1.4404 / AISI 316L |
| | Surface: | Ra ≤ 0,8µm |
| | Sealing material: | EPDM |
| | | HNBR NBR FKM |

5 Disassembly and assembly

5.1 Disassembly

Disassembly

- Unscrew the slotted nut (1).
- Remove the strainer insert (5) from the housing (3).
- Remove seal (2) and O-ring (6).

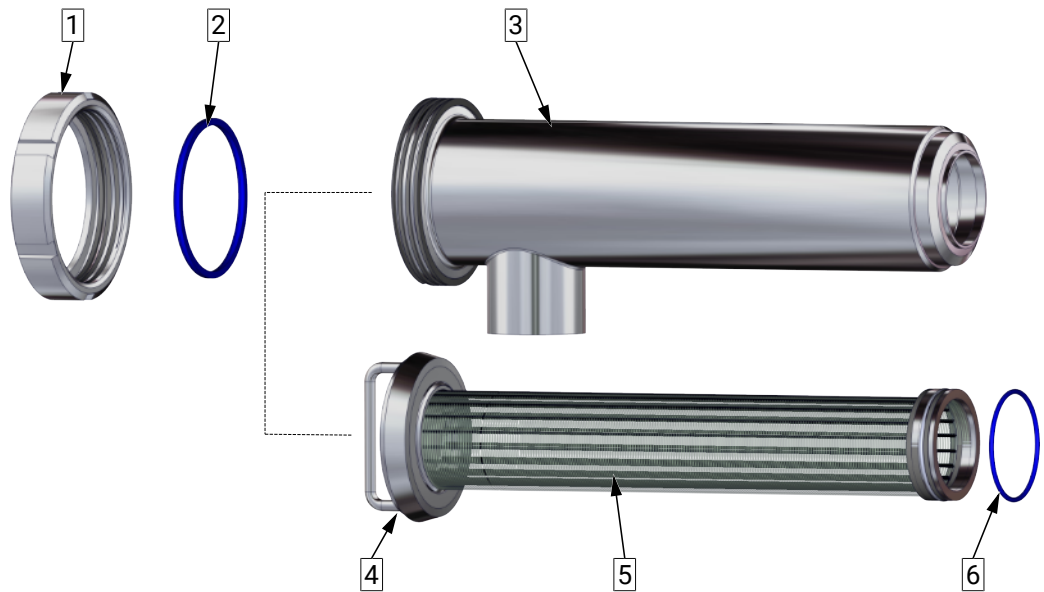

| | |
|-------------------|----------------|
| 1 Slotted nut | 2 Sealing ring |
| 3 Housing | 4 Liner |
| 5 Strainer insert | 6 O-ring |

Lubricant recommendation

| | | |
|---|------------------------------|----------------------------|
|  | EPDM; HNBR; NBR; FKM; k-flex | - Klüber Paraliq GTE703* |
| | Silicone | - Klüber Sintheso pro AA2* |
| | Thread | - Interflon Food* |
| *) It is only permitted to use approved lubricants, if the respective fitting is used for the production of food or drink. Please observe the relevant safety data sheets of the manufacturers of lubricants. | | |

5.2 Assembly

Assembly

- Before installation, thoroughly clean and slightly lubricate mounting areas and running surfaces.
- Assemble in reverse order.

6 Drawings and dimensions

6.1 Drawings

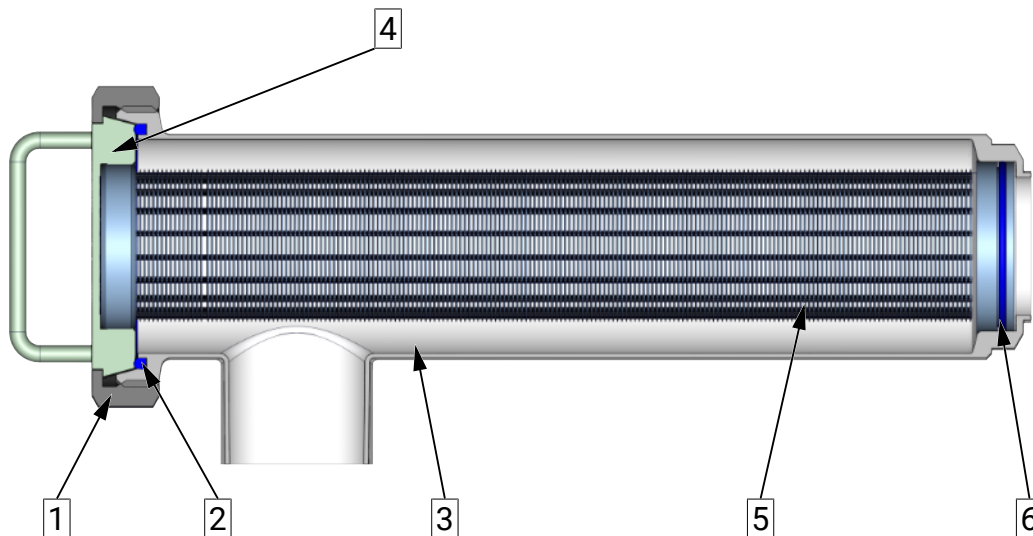
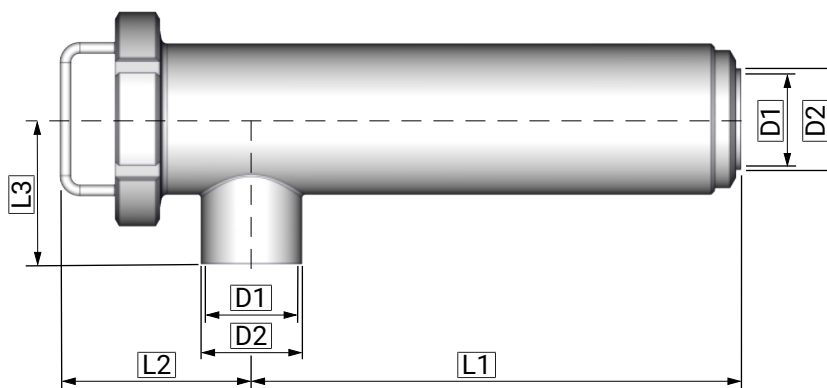

Fig. 1 Example drawing with welding connection

| | |
|-------------------|----------------|
| 1 Slotted nut | 2 Sealing ring |
| 3 Housing | 4 Liner |
| 5 Strainer insert | 6 O-ring |

6.2 Dimensions

Angle tube strainer with welding ends (S - S)



| Nominal size | Ø D1 | Ø D2 | L1 | L2 | L3 | Nominal size | Ø D1 | Ø D2 | L1 | L2 | L3 |
|--------------|------|------|-----|-----|-----|--------------|------|------|-----|-----|-----|
| DN 25 | 26 | 29 | 319 | 103 | 67 | DN 80 | 81 | 85 | 552 | 211 | 113 |
| DN 32 | 32 | 35 | 319 | 104 | 75 | DN 100 | 100 | 104 | 550 | 185 | 125 |
| DN 40 | 38 | 41 | 309 | 115 | 77 | DN 125 | 125 | 129 | 549 | 303 | 162 |
| DN 50 | 50 | 53 | 320 | 119 | 87 | DN 150 | 150 | 154 | 607 | 353 | 165 |
| DN 65 | 66 | 70 | 337 | 132 | 100 | | | | | | |

Table 1 Dimensions [mm]

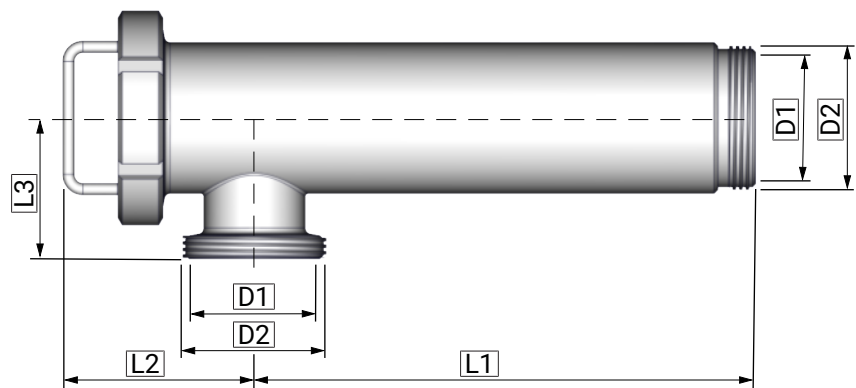
Angle tube strainer with threaded connection (G - G)

| Nominal size | Ø D1 | Ø D2 | L1 | L2 | L3 |
|--------------|------|--------------|-----|-----|-----|
| DN 25 | 26 | Rd 52 x 1/6 | 327 | 103 | 61 |
| DN 32 | 32 | Rd 58 x 1/6 | 327 | 104 | 71 |
| DN 40 | 38 | Rd 65 x 1/6 | 316 | 115 | 72 |
| DN 50 | 50 | Rd 78 x 1/6 | 327 | 119 | 82 |
| DN 65 | 66 | Rd 95 x 1/6 | 345 | 132 | 97 |
| DN 80 | 81 | Rd 110 x 1/4 | 560 | 211 | 115 |
| DN 100 | 100 | Rd 130 x 1/4 | 560 | 185 | 136 |
| DN 125 | 125 | Rd 160 x 1/4 | 560 | 303 | 162 |
| DN 150 | 150 | Rd 190 x 1/4 | 620 | 353 | 165 |

Table 2 Dimensions [mm]

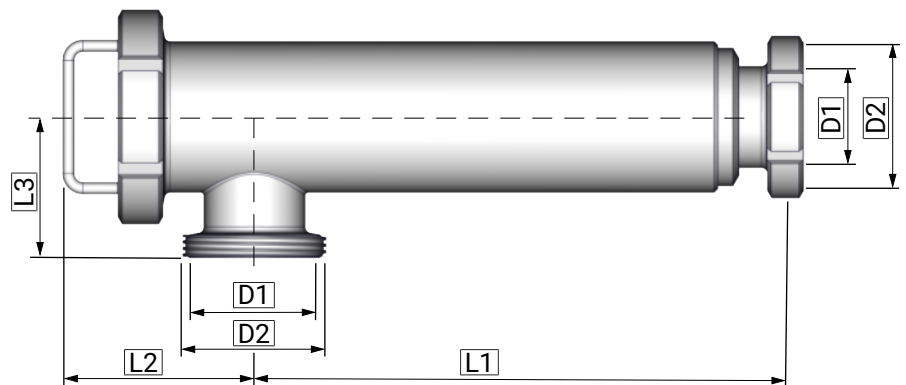
Angle tube strainer with union connection (K/M - G)

| Nominal size | Ø D1 | Ø D2 | L1 | L2 | L3 |
|--------------|------|--------------|-----|-----|-----|
| DN 25 | 26 | Rd 52 x 1/6 | 327 | 103 | 61 |
| DN 32 | 32 | Rd 58 x 1/6 | 327 | 104 | 71 |
| DN 40 | 38 | Rd 65 x 1/6 | 316 | 115 | 72 |
| DN 50 | 50 | Rd 78 x 1/6 | 327 | 119 | 82 |
| DN 65 | 66 | Rd 95 x 1/6 | 345 | 132 | 97 |
| DN 80 | 81 | Rd 110 x 1/4 | 560 | 211 | 115 |
| DN 100 | 100 | Rd 130 x 1/4 | 560 | 185 | 136 |
| DN 125 | 125 | Rd 160 x 1/4 | 560 | 303 | 162 |
| DN 150 | 150 | Rd 190 x 1/4 | 620 | 353 | 165 |

Table 3 Dimensions [mm]

7 Wearing parts

7.1 Wearing parts list

| Nominal size | EPDM | | HNBR | |
|--------------|------------------|------------------|------------------|------------------|
| | Pos. 2 Seal | Pos. 6 O-ring | Pos. 2 Seal | Pos. 6 O-ring |
| DN 25 | 2005 050 000-054 | 2304 035 030-170 | 2004 050 000-050 | 2304 036 035-050 |
| DN 32 | 2005 065 000-054 | 2304 042 030-170 | 2004 065 000-050 | 2304 042 030-050 |
| DN 40 | 2005 065 000-054 | 2304 042 030-170 | 2004 065 000-050 | 2304 042 030-050 |
| DN 50 | 2005 080 000-054 | 2304 057 035-159 | 2004 080 000-050 | 2304 057 035-050 |
| DN 65 | 2005 100 000-054 | 2304 069 035-159 | 2004 100 000-050 | 2304 069 035-050 |
| DN 80 | 2005 125 000-054 | 2304 085 035-159 | 2004 125 000-050 | 2304 085 035-157 |
| DN 100 | 2005 150 000-054 | 2304 104 030-170 | 2004 150 000-050 | 2304 104 030-050 |
| DN 125 | 2005 125 000-054 | 2304 125 035-159 | 2004 125 000-050 | 2304 125 035-050 |
| DN 150 | 2004 150 000-054 | 2304 151 030-054 | 2004 150 000-050 | 2304 151 030-050 |

| Nominal size | NBR | | FKM | |
|--------------|------------------|------------------|------------------|------------------|
| | Pos. 2 Seal | Pos. 6 O-ring | Pos. 2 Seal | Pos. 6 O-ring |
| DN 25 | 2004 050 000-056 | 2304 036 030-055 | 2008 050 000-051 | 2304 036 030-051 |
| DN 32 | 2004 065 000-056 | 2304 042 030-055 | 2008 065 000-051 | 2304 042 030-051 |
| DN 40 | 2004 065 000-056 | 2304 042 030-055 | 2008 065 000-051 | 2304 042 030-051 |
| DN 50 | 2004 080 000-056 | 2304 059 035-055 | 2008 080 000-051 | 2304 054 035-051 |
| DN 65 | 2004 100 000-056 | 2304 070 035-055 | 2008 100 000-051 | 2304 070 035-051 |
| DN 80 | 2004 125 000-056 | 2304 085 035-055 | 2008 125 000-051 | 2304 085 035-051 |
| DN 100 | 2004 150 000-056 | 2304 104 030-055 | 2008 150 000-051 | 2304 108 030-051 |
| DN 125 | 2004 125 000-056 | 2304 125 035-055 | 2008 125 000-051 | 2304 125 035-051 |
| DN 150 | 2004 150 000-056 | 2304 150 030-055 | 2008 150 000-051 | 2304 150 030-051 |