



# KIESELMANN

FLUID PROCESS GROUP

Translation of the original

## Operating Instructions

### Vacuum valves

Type 6164

weight-loaded

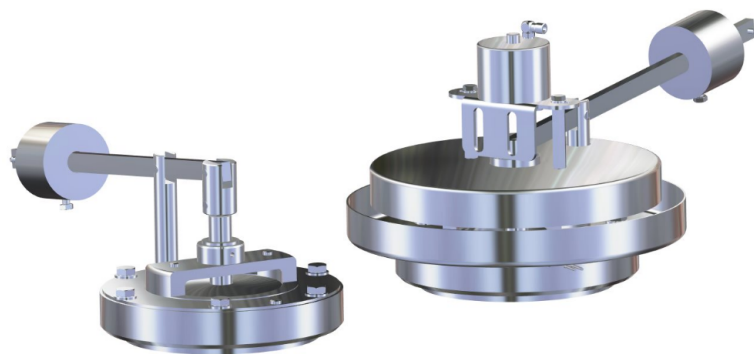

**KIESELMANN GmbH**

Paul-Kieselmann-Str. 4-10  
D - 75438 Knittlingen

 +49(0) 7043 371-0 •  +49(0) 7043 371-125  
[www.kieselmann.de](http://www.kieselmann.de) • [info@kieselmann.de](mailto:info@kieselmann.de)

---

Copyright: © KIESELMANN FLUID PROCESS GROUP

## Table of contents

<b>1</b>	<b>General informations</b>	<b>4</b>
1.1	Informations for your safety	4
1.2	Marking of security instructions	4
1.3	General designated use	4
1.4	Personnel	4
1.5	Modifications, spare parts, accessories	5
1.6	General instructions	5
<b>2</b>	<b>Safety instructions</b>	<b>6</b>
2.1	Intended use	6
2.2	General notes	6
2.3	General safety instructions	6
<b>3</b>	<b>Delivery, transport and storage</b>	<b>8</b>
3.1	Delivery	8
3.2	Transport	8
3.3	Storage	8
<b>4</b>	<b>Function and operation</b>	<b>9</b>
4.1	Description of function	9
4.2	Commissioning, service and maintenance	9
4.2.1	Commissioning	9
4.2.2	General welding guidelines	9
4.2.3	Use in EX area	9
4.2.4	Service	9
4.2.5	Cleaning	10
4.3	Pressure setting	10
<b>5</b>	<b>Technical data</b>	<b>11</b>
5.1	Vacuum valve	11
5.2	Identification	11
5.3	Pneumatic actuator	12
5.4	heating system	12
<b>6</b>	<b>Disassembly and assembly</b>	<b>14</b>
6.1	Disassembly	14
6.2	Assembly	15
<b>7</b>	<b>Drawings and dimensions</b>	<b>16</b>
7.1	Drawings	16
7.2	Dimensions	18
<b>8</b>	<b>Wearing parts</b>	<b>20</b>
<b>9</b>	<b>Characteristic curves</b>	<b>21</b>
9.1	Performance chart	21
<b>10</b>	<b>Appendix</b>	<b>23</b>
10.1	Declaration of incorporation	23

## 1 General informations

### 1.1 Informations for your safety

We are pleased that you have decided for a high-class KIESELMANN product. With correct application and adequate maintenance, our products provide long time and reliable operation.





Before installation and initiation, please carefully read this instruction manual and the security advices contained in it. This guarantees reliable and safe operation of this product and your plant respectively. Please note that an incorrect application of the process components may lead to great material damages and personal injury.

In case of damages caused by non observance of this instruction manual, incorrect initiation, handling or external interference, guarantee and warranty will lapse!

Our products are produced, mounted and tested with high diligence. However, if there is still a reason for complaint, we will naturally try to give you entire satisfaction within the scope of our warranty. We will be at your disposal also after expiration of the warranty. In addition, you will also find all necessary instructions and spare part data for maintenance in this instruction manual. If you don't want to carry out the maintenance by yourself, our KIESELMANN - service team will naturally be at your disposal.

### 1.2 Marking of security instructions

Hints are available in the chapter "safety instructions" or directly before the respective operation instruction. The hints are highlighted with a danger symbol and a signal word. Texts beside these symbols have to be read and adhered to by all means. Please continue with the text and with the handling at the valve only afterwards.

Symbol	Signal word	Meaning
	DANGER	Imminent danger which will result severe personal injury or death.
	WARNING	Imminent danger which may result severe personal injury or death.
	CAUTION	Dangerous situation which may cause slight personal injury or material damages.
	NOTICE	An harmful situation which may result in damages of the product itself or of adjacent vicinity.
	INFORMATION	Marks application hints and other information which is particularly useful.

### 1.3 General designated use

The fitting is designed exclusively for the purposes described below. Using the fitting for purposes other than those mentioned is considered contrary to its designated use. KIESELMANN cannot be held liable for any damage resulting from such use. The risk of such misuse lies entirely with the user. The prerequisite for the reliable and safe operation of the fitting is proper transportation and storage as well as competent installation and assembly. Operating the fitting within the limits of its designated use also involves observing the operating, inspection and maintenance instructions.

### 1.4 Personnel

Personnel entrusted with the operation and maintenance of the tank safety system must have the suitable qualification to carry out their tasks. They must be informed about possible dangers and must understand and observe the safety instructions given in the relevant manual. Only allow qualified personnel to make electrical connections.

## 1.5 Modifications, spare parts, accessories

Unauthorized modifications, additions or conversions which affect the safety of the fitting are not permitted. Safety devices must not be bypassed, removed or made inactive. Only use original spare parts and accessories recommended by the manufacturer.

## 1.6 General instructions

The user is obliged to operate the fitting only when it is in good working order. In addition to the instructions given in the operating manual, please observe the relevant accident prevention regulations, generally accepted safety regulations, regulations effective in the country of installation, working and safety instructions effective in the user's plant.

## 2 Safety instructions

### 2.1 Intended use

This vacuum valve is used to prevent underpressure in tanks and vessels in plants of the food and drink industry, pharmaceutical and chemical industries as well as in biotechnology.

### 2.2 General notes



#### NOTICE - observe the operating instructions

To avoid danger and damage, the fitting must be used in accordance with the safety instructions and technical data contained in the operating instructions.



#### NOTICE

All data are in line with the current state of development. Subject to change as a result of technical progress.

### 2.3 General safety instructions



#### WARNING

##### Risk of injury by outflowing medium

Dismantling the valve or valve assemblies from the plant can cause injuries.

- Medias flowing through the leakage drain outlet are to be drained off without splashing into a discharge arrangement.
- Carry the disassembling only if when the plant has been rendered pressure-less and free of liquid and gas.



#### WARNING

##### Functional impairment at low temperatures

Referring to the used sealing materials the vacuum valves are suitable for a minimum operating temperature at -10 °C.

- Low operating or ambient temperatures may applicable a impairment the function.
  - Therefore, appropriate measures shall be taken for an operation at temperatures below +5°C to ensure a safe function of the valve.



#### CAUTION

##### Damage to the tank

The action of external force on the lever mechanism results in changes in the opening characteristics. This can result in damage to the tanks.



#### CAUTION

##### Malfunction due to contamination

Internal or external dirt may impair the function of the fitting or the safety equipment.

- Therefore the fitting must be operated in a way that protects it from external influences.
  - The fitting must be cleaned internal and external at regular intervals.
  - The fitting must be maintained at regular intervals.
  - The fitting must be checked for its function at regular intervals.

**⚠ CAUTION**

**Remove transport insurance before initial operation.**

---

## 3 Delivery, transport and storage

### 3.1 Delivery

- Immediately after receipt check the delivery for completeness and transport damages.
- Remove the packaging from the product.
- Retain packaging material, or expose of according to local regulations.

### 3.2 Transport



#### CAUTION

##### **Risk of injury and damage to the product**

During the transport the generally acknowledged rules of technology, the national accident prevention regulations and company internal work and safety regulations must be observed.

### 3.3 Storage



#### NOTICE

##### **Damage to the product due to improper storage!**

Observe storage instructions  
avoid a prolonged storage



#### INFORMATION

##### **Recommendation for longer storage**

We recommend regularly checking the product and the prevailing storage conditions during long storage times.

- To avoid damage to seals and bearings,
  - products up to DN 125 / OD 5 inch should be stored horizontally for maximum 6 months.
  - products larger than DN 125 / 5 inch, should be stored in the upright position with the actuator on top.
- Don't store any objects on the products.
- Protect the products for wetness, dust and dirt.
- The product should be stored in a dry and well ventilated room at a constant temperature (optimal indoor temperature: 25 C ±5 ; indoor humidity data 70% ±5%).
- Protect seals, bearings and plastic parts for UV light and ozone.



## 4 Function and operation

### 4.1 Description of function

The function of the vacuum valve is to prevent impermissible pressure shortfalls ( $\leq 1$  bar absolute pressure), in tanks and containers, which can result in damage. At underpressure, the valve opens to the atmosphere. The pressure in the tank is brought to the atmospheric pressure by the inflowing air. When the pressures become equal, the valve closes by the force of its weight without any external energy. The flow capacities referred to the relevant underpressure are shown in the capital Characteristic curves.

In addition, the valve can be operated via a pneumatic actuator (see chapter Pneumatic actuator [► 12]). The position of the actuator can be retrieved via sensors which are mounted at a sensor mounting.

### 4.2 Commissioning, service and maintenance

#### 4.2.1 Commissioning

##### 4.2.1.1 Installation instructions

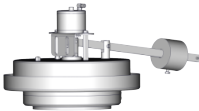

#### Fitting position

- The fitting is generally install vertical, as shown in the picture.

#### 4.2.2 General welding guidelines

Sealing elements integrated in weld components must generally be removed prior to welding. To prevent damage, welding should be undertaken by certified personnel (EN ISO 9606-1). Use the TIG (Tungsten Inert Gas) welding process.



#### ⚠ CAUTION

##### Damage and injuries due to high temperature supply

To avoid a distortion of the components, all welding parts must be welded to stress-relieved. Allow all components to cool before assembling.



#### NOTICE

##### Damage due to impurities

Impurities can cause damage to the seals and seals area. Clean inside areas prior to assembly.

#### 4.2.3 Use in EX area

For valves or plants/installations that are operated in the ATEX area, sufficient bonding (grounding) must be ensured. (see e.g. ATEX Directives EC; UKSI 696:2019-Schedule 25)

#### 4.2.4 Service



#### RECOMMENDATION

##### Replacement of seals

To achieve optimal maintenance cycles, the following points must be observed!

- When replacement of seals, all product-contacting seals should be replaced.
- Only original spare parts may be installed.

### Maintenance interval

The maintenance intervals depend on the operating conditions "temperature, temperature-intervals, medium, cleaning medium, pressure and opening frequency". We recommend replacing the seals *1-year cycle*. The user, however should establish appropriate maintenance intervals according to the condition of the seals.

### Lubricant recommendation

	EPDM; HNBR; NBR; FKM; k-flex	- Klüber Paraliq GTE703*
	Silicone	- Klüber Sintheso pro AA2*
	Thread	- Interflon Food*
*) It is only permitted to use approved lubricants, if the respective fitting is used for the production of food or drink. Please observe the relevant safety data sheets of the manufacturers of lubricants.		

## 4.2.5 Cleaning

### Cleaning

The optimum cleaning is carried out with the tank or pipe cleaning.

## 4.3 Pressure setting

The vacuum valve is set at the factory, by correspondingly positioning the weight, to an underpressure of 3 mbar. At this underpressure, the valve opens to the atmosphere.

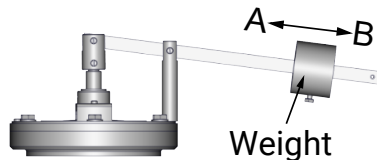

### NOTICE

If the position of the weight is changed towards direction (A), the closing function is not guaranteed any more.

If the position of the weight is changed towards direction (B), then the water column (Wc) increase on the maximum water column Wcmax.

Water column [Wc] = Wassersäule [WS]

DN	50	65	100	125	150	200	250
	Lever: long / short						
Ws <sub>min</sub> (mm)	30	30	30	30	30/30	30/30	30/30
Ws <sub>max</sub> (mm)	150	50	150	240	320/120	125/100	370/80

## 5 Technical data

### 5.1 Vacuum valve

Model	Venting valve	
	<ul style="list-style-type: none"> <li>• weight-loaded</li> <li>• pneumatically liftable</li> <li>• optionally with heating element, temperature sensor, sensor mounting</li> </ul>	
Size	DN 50; DN 65; DN 100 - DN 250	
Connection type	<ul style="list-style-type: none"> <li>• Flange connection</li> <li>• Flange with weld-on end end DIN EN 10357</li> </ul>	
Operating pressure	DN 50	PN 16
	DN 65; DN 100	PN 10
	DN 125; DN 150	PN 16
	DN 200; DN 250	PN 10
Set pressure	3 mbar (30 mmWS) (factory setting)	
Temperature range	Operating temperature:	+0° to +100°C
	(depends on medium)	
	Sterilisation temperature:	HNBR +100°C
	(SIP 30 min)	EPDM +140°C
		VMQ +90°C
Material (in contact with product)	Stainless steel:	1.4301 / AISI 304
	Surface:	Ra < 0,8µm mat finish
	Sealing material:	<ul style="list-style-type: none"> <li>• EPDM</li> <li>• HNBR</li> <li>• VMQ</li> </ul>

### 5.2 Identification

Identification 1  
lasered

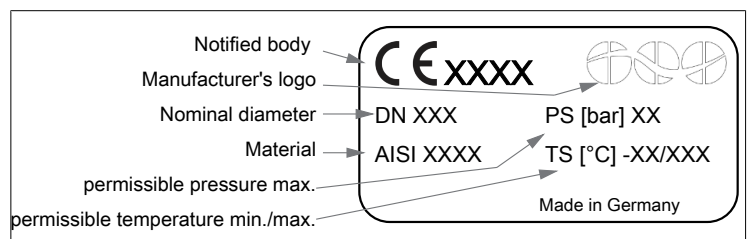

Identification 2  
bonded

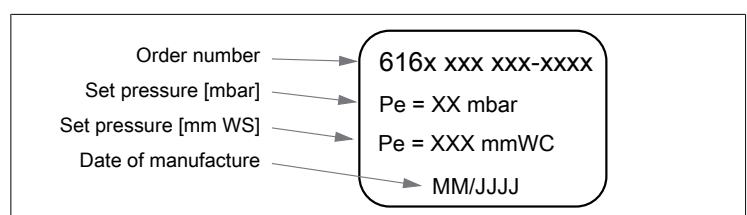

### 5.3 Pneumatic actuator

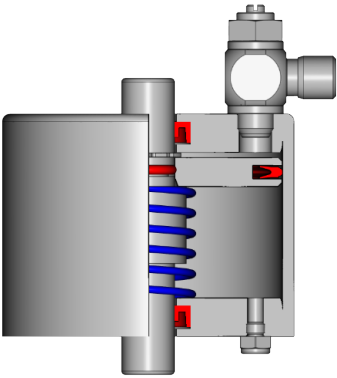
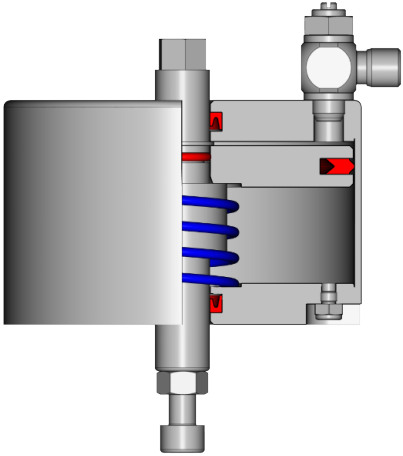
Type 76 6162 076 900 – 032		Type 104 6162 104 900 – 032	
			
Total height	85 mm	Total height	97 mm
Installation height	67 mm	Installation height	83 mm
Outside diameter	76 mm	Outside diameter	104 mm
Stroke	9 mm	Stroke	9 mm
Lifting force <sup>*)</sup>	1.844 N	Lifting force <sup>*)</sup>	3.822 N
weight	1,05 kg	weight	2,1 kg
*) at at control air pressure: 5 bar <sub>(g)</sub> Quality of control air ISO 8573-1:2010 quality class 3			

The selection of the actuator size can be made according to the following table:

Nominal size	Control air pressure	Acuator type at Overpressure in the Vessel				
		0,5 bar	0,7 bar	1,0 bar	1,5 bar	2,0 bar
DN 50	5 bar	Ø 76	Ø 76	Ø 76	Ø 76	Ø 76
DN 65	5 bar	Ø 76	Ø 76	Ø 76	Ø 76	Ø 76
DN 100	5 bar	Ø 76	Ø 76	Ø 76	Ø 76	Ø 76
DN 125	5 bar	Ø 76	Ø 76	Ø 76	Ø 76	-
DN 150	5 bar	Ø 104	Ø 104	Ø 104	Ø 104	-
DN 200	5 bar	Ø 104	Ø 104	Ø 104	-	-
DN 250	5 bar	Ø 104	Ø 104	-	-	-

### 5.4 heating system

The heating of the vacuum valves via resistance heating cable with a defined heating zone, which run in an annular groove in the housing flange.

The heat tracing must be operated with a temperature control, so that exceeding the limit temperatures of the electric heating cables and the products to be heated is not exceeded. In the hole (B), a sensor (Ø5mm) can be used for temperature monitoring.

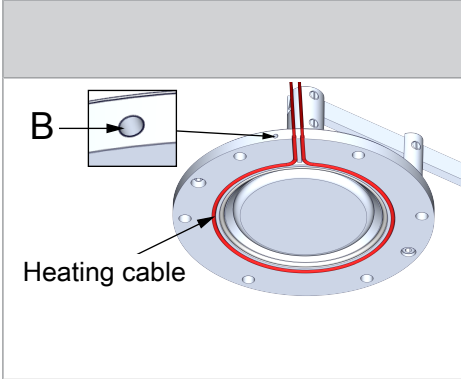
	Size	Usable cable length	Article number
	DN 50	-	-
	DN 65	382 mm	8615 483 038 - 000
	DN 100	525 mm	8615 483 052 - 000
	DN 125	622 mm	8615 483 062 - 000
	DN 150	738 mm	8615 483 073 - 000
	DN 200	888 mm	8615 483 088 - 000
	DN 250	1.074 mm	8615 483 107 - 000
	-	1.100 mm	8615 483 110 - 000

## 6 Disassembly and assembly

### 6.1 Disassembly



#### NOTICE

All threaded joints have right-hand thread.

Dismantle pneumatic and electrical connections. Unscrew fittings for CIP, discharge and feed lines.

#### Pneumatic actuator

Unscrew the screws (A).

Remove the pneumatic actuator with bracket.

Unscrew the screws (B) and remove the bracket.

Unscrew the bolts.

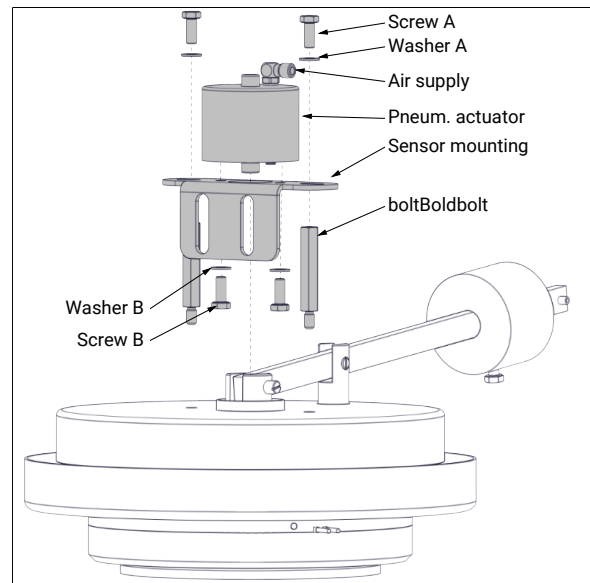

#### splash guard

Unscrew the set screw.

Remove the lever with the weight and the splash guard.

Unscrew the screws.

Remove the flange, O-ring and heating element.

Remove the inner splash guard.

Unscrew the bolts.

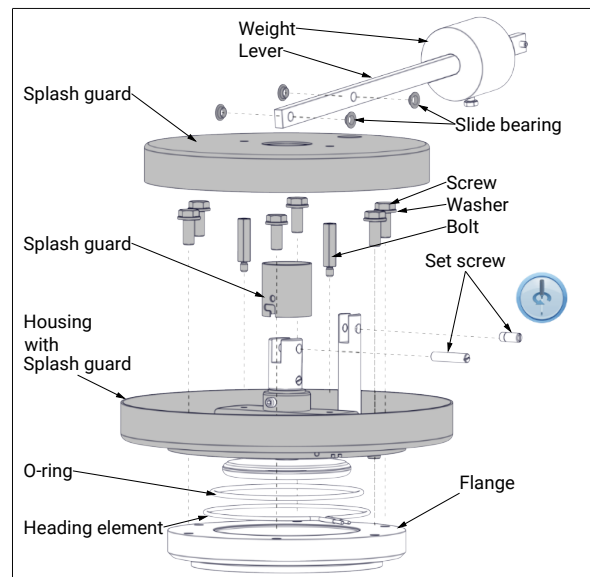

### Basic valve

- DN 65- DN 250

Unscrew set screw.

Remove the joint.

- DN50 - DN100

Remove circlip ring.

Remove downwards the shaft with plate A and plate B.

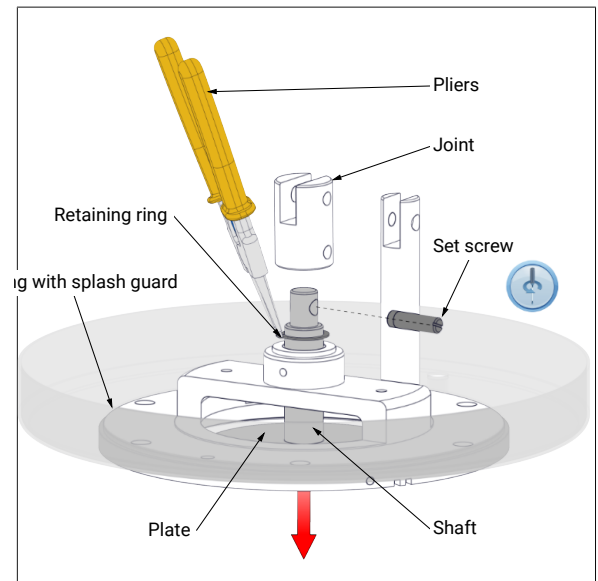

Tighten the plate B between soft jaws in a vice.

Unscrew with a fit round rod the shaft from the plate B.

Remove O-ring.

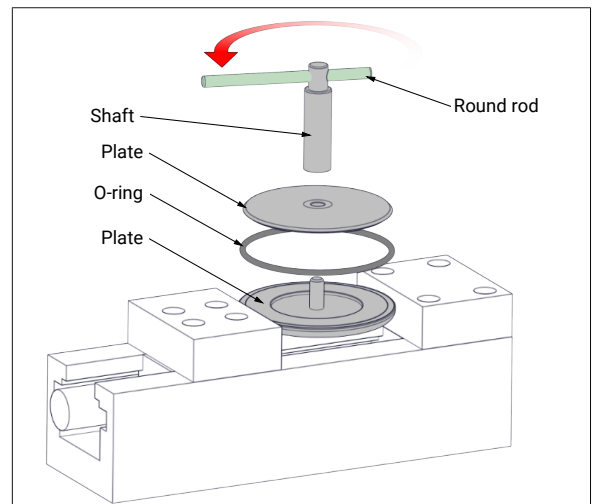

## 6.2 Assembly

- Thoroughly clean and slightly lubricate mounting areas and running surfaces.  
Assemble in reverse order.
- Check valve functions.



### NOTICE

Thoroughly clean the plate and the shaft and secure the thread connection with removable screw retention.

## 7 Drawings and dimensions

### 7.1 Drawings

#### Vacuum valve - basic version

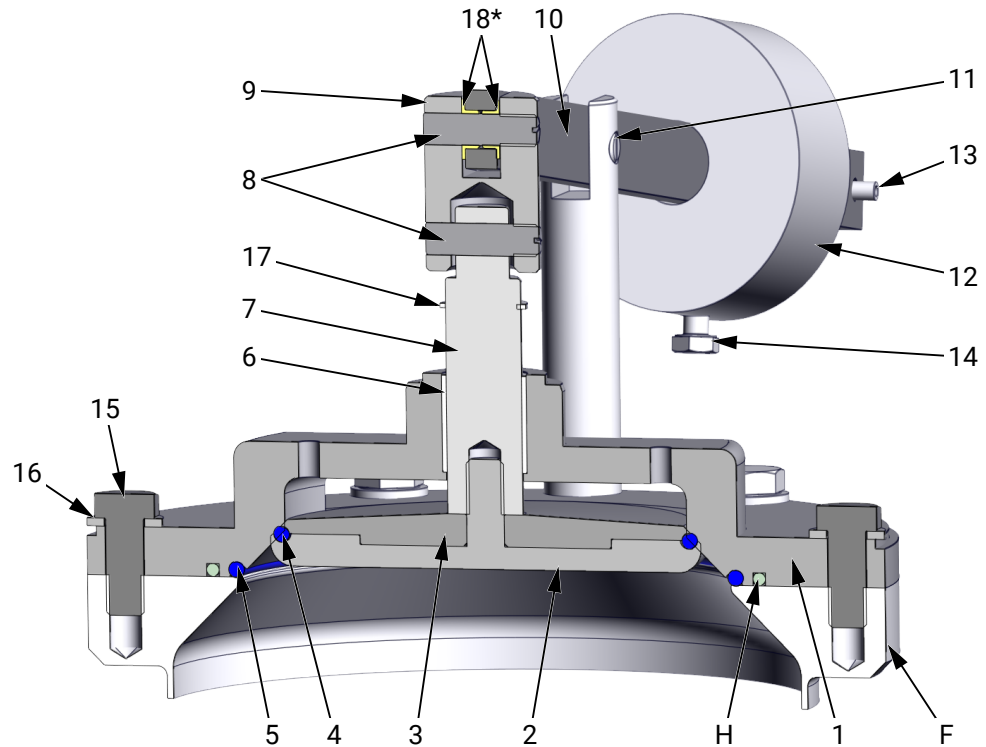

1 Housing	2 Plate
3 Plate	4 O-ring
5 O-ring	6 Slide bearing
7 Shaft	8 Set screw
9 Joint	10 Lever
11 Set screw	12 Weight
13 Dowel pin	14 Screw
15 Screw	16 Washer
17 Locking ring	18* Slide bearing
F Flange	H Heading element

\*)  $\geq$  DN 125



## Version with pneumatic lifting device and splash guard

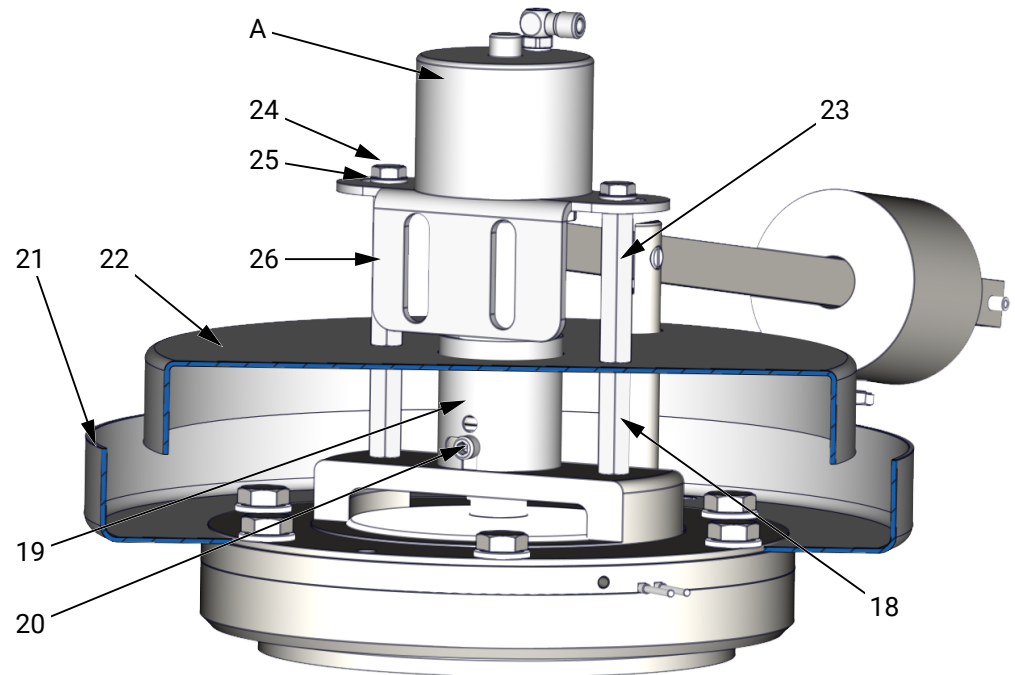

18 Bolt	19 Splash guard
20 Allen screw	21 Trip tray
22 Splash guard	23 Bolt
24 Screw	25 Washer
26 Sensor mounting	A Actuator

## 7.2 Dimensions

### Vacuum valve - basic version

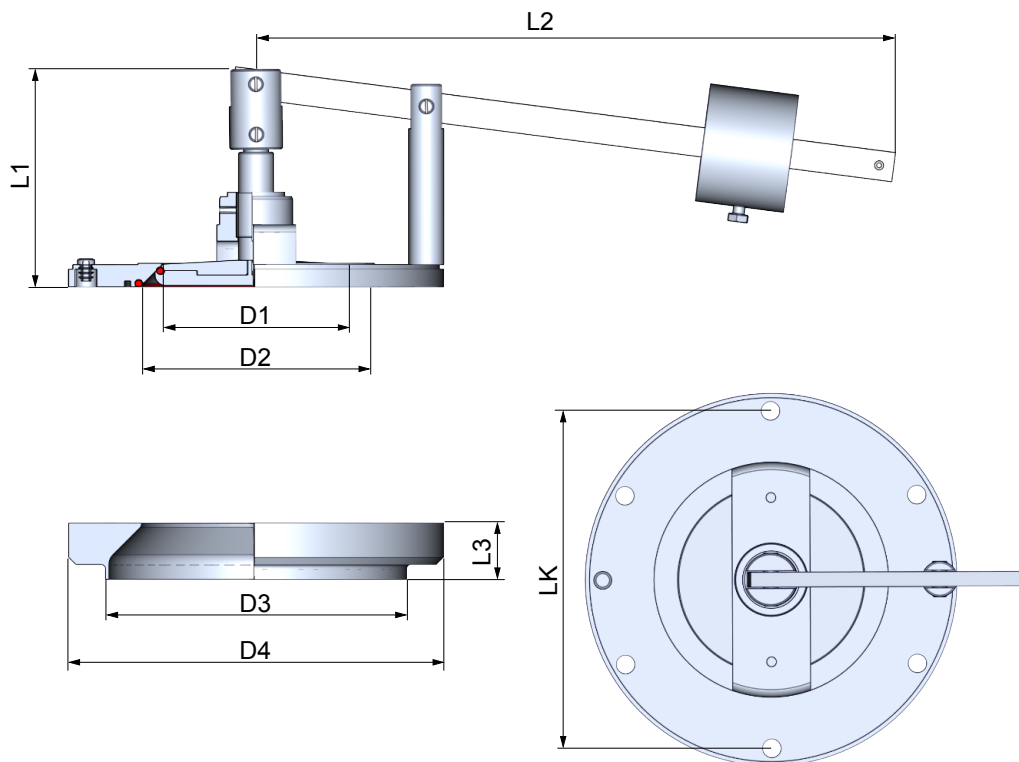

DN	Dimension [mm]								
	D1	D2	D3	D4	LK Bolt circle	L1	L2 <sup>1</sup>	L3	M
50	55	74	85 x 2,0	129	115 [4 x M10]	112	229	26	150
65	68	91	104 x 2,0	154	130 [4 x M8]	126	235	29	165
100	104	131	154 x 2,0	204	180 [6 x M8]	130	334	30	180
125	128	155	204 x 2,0	254	230 [6 x M12]	150	433	38	200
150	152	180	254 x 2,0	304	260 [6 x M12]	149	433 / ?	39	210
200	204	243	304 x 2,0	326	300 [8 x M12]	201	426 / 673	40	275
250	252	298	354 x 2,0	406	355 [8 x M12]	219	481 / 673	54	335

1. L2 = short lever / long lever

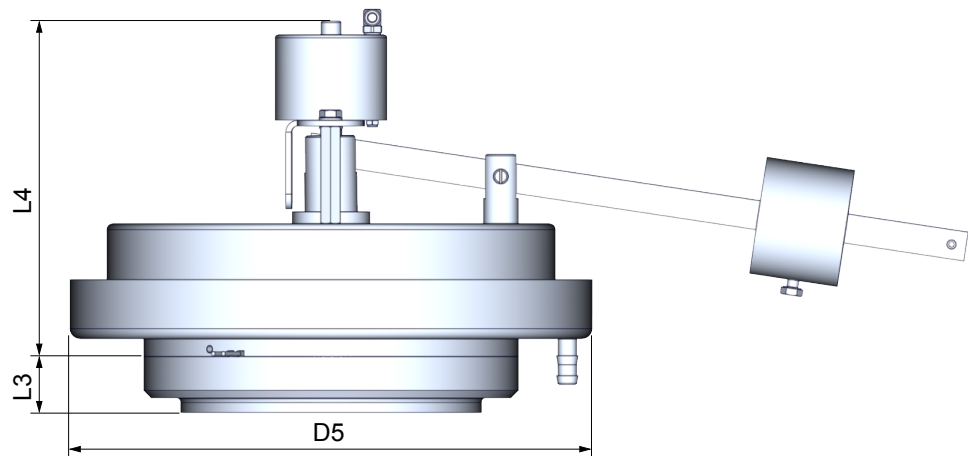
**Version with pneumatic lifting device and splash guard**

DN	Dimension [mm]		
	D5	L3	L4
50	196	26	198
65	230	29	214
100	279	30	217
125	354	38	235
150	366	39	260
200	412	40	311
250	481	54	333

## 8 Wearing parts

DN	Wear parts kit	O-ring (4)	O-ring (5)	Locking ring (17)
	EPDM	EPDM	EPDM	1.4310 / AISI 301
50	6164 050 990-300	2304 050 050-054	2304 083 050-170	8084 015 100-030
65	6164 065 990-300	2304 065 050-054	2304 090 050-170	8084 020 120-031
100	6164 100 990-300	2304 100 050-054	2304 130 050-170	8084 020 120-031
125	6164 125 990-300	2304 125 050-054	2304 152 050-170	-
150	6164 150 990-300	2304 150 050-054	2304 183 050-170	-
200	6164 200 990-300	2304 200 050-054	2304 242 050-170	-
250	6164 250 990-300	2304 250 060-054	2304 300 050-054	8146 035 025-031

## 9 Characteristic curves

### 9.1 Performance chart



#### NOTICE

The flow capacities as well as the characteristic curves refer to the factory setting with a default set pressure of 3 mbar (30 mm WC). With this setting a steady flow characteristic will be achievable at a differential pressure of 5 mbar (50 mm WC). Changing the set pressure will affect the performance characteristics and the course of the characteristic curve.

#### Flow characteristics for vacuum valves - basic version

Flow capacity							
$\Delta p$	DN 50	DN 65	DN 100	DN 125	DN 150	DN 200	DN 250
[mbar]	[m <sup>3</sup> /h]	[m <sup>3</sup> /h]	[m <sup>3</sup> /h]	[m <sup>3</sup> /h]	[m <sup>3</sup> /h]	[m <sup>3</sup> /h]	[m <sup>3</sup> /h]
5	50	147	366	405	470	1.332	2.199
10	141	208	517	765	957	1.866	3.112
15	173	255	634	937	1.173	2.311	3.815
20	200	295	733	1.083	1.356	2.671	4.409
25	224	330	820	1.212	1.517	2.990	4.934
30	245	361	899	1.329	1.664	3.278	5.140
35	265	391	972	1.437	1.799	3.544	5.849
40	284	418	1.041	1.538	1.925	3.792	6.258
45	301	444	1.105	1.633	2.043	4.026	6.644
50	318	468	1.166	1.723	2.156	4.248	7.010
55	334	492	1.224	1.808	2.263	4.459	7.359
60	349	514	1.279	1.890	2.366	4.662	7.694

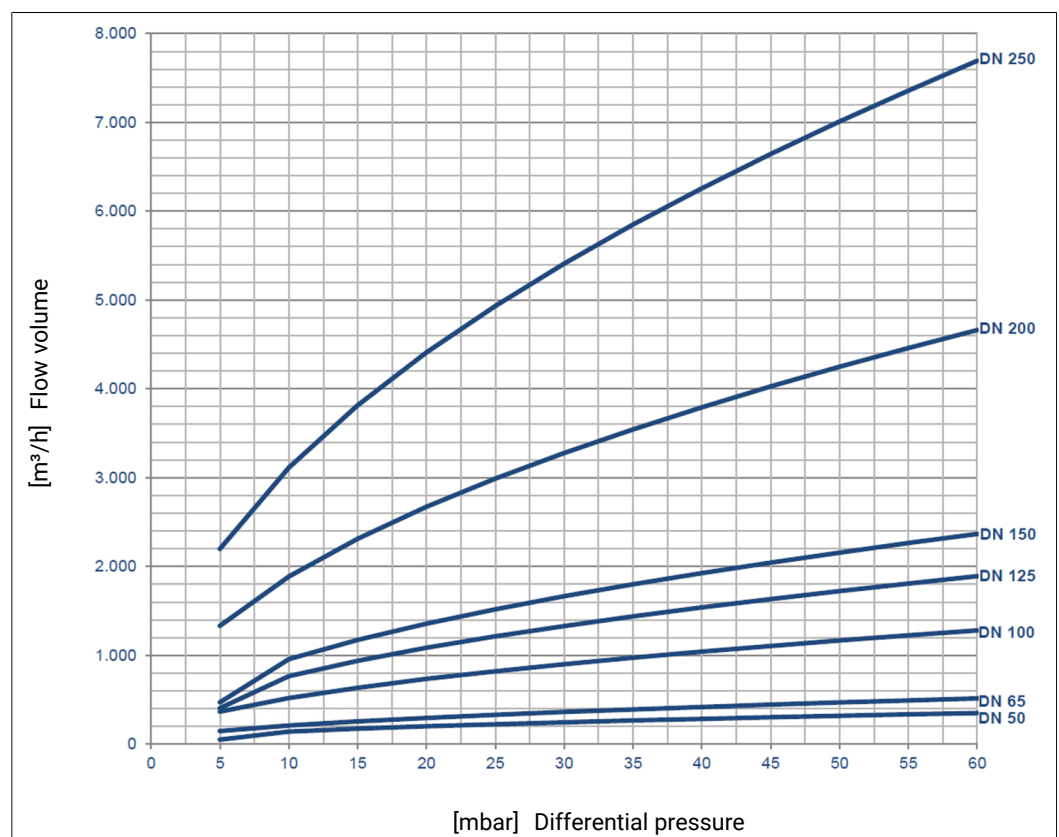

**Flow characteristics for vacuum valves with splash guard**

Flow capacity							
$\Delta p$	DN 50	DN 65	DN 100	DN 125	DN 150	DN 200	DN 250
[mbar]	[m <sup>3</sup> /h]	[m <sup>3</sup> /h]	[m <sup>3</sup> /h]	[m <sup>3</sup> /h]	[m <sup>3</sup> /h]	[m <sup>3</sup> /h]	[m <sup>3</sup> /h]
5	46	137	340	377	437	1239	2045
10	131	192	479	707	885	1744	2879
15	159	235	584	862	1079	2127	3510
20	183	270	671	991	1241	2444	4034
25	204	300	747	1103	1381	2720	4490
30	222	327	814	1203	1506	2966	4896
35	239	352	875	1293	1619	3189	5264
40	253	372	926	1369	1713	3375	5570
45	265	391	972	1437	1798	3543	5847
50	277	408	1014	1499	1876	3695	6099
55	287	423	1052	1555	1946	3835	6329
60	297	437	1087	1607	2011	3962	6540

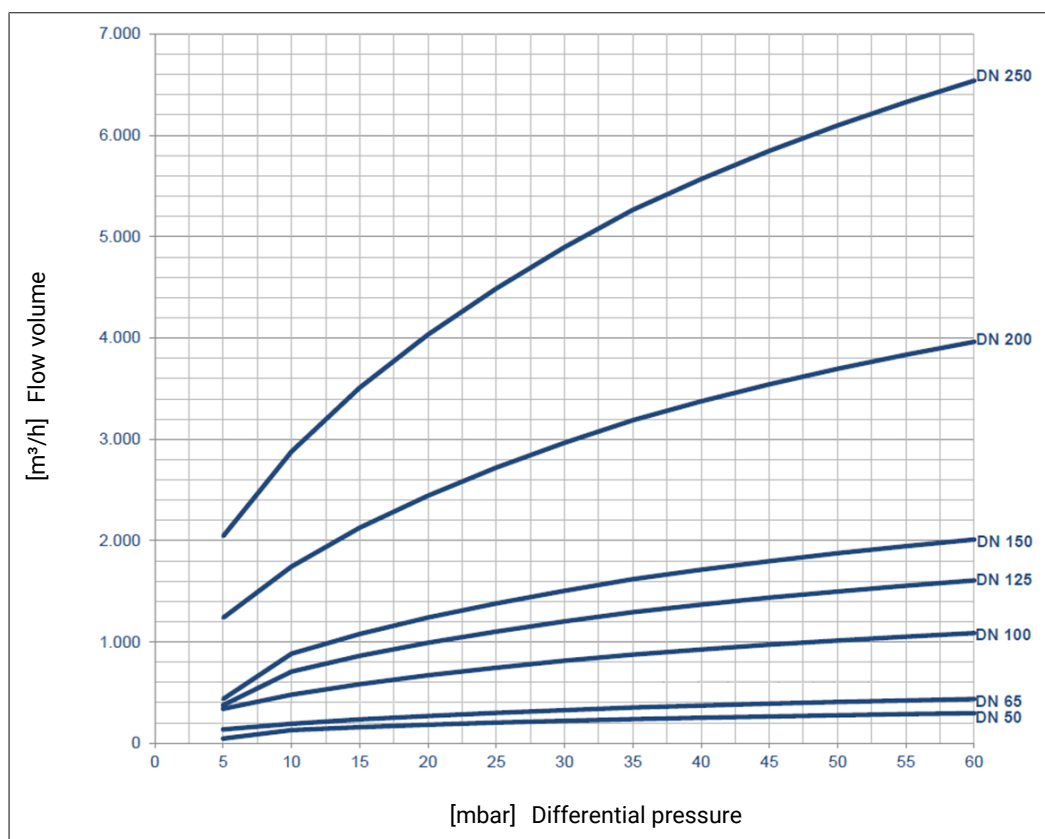

## 10 Appendix

### 10.1 Declaration of incorporation

#### Declaration of Incorporation

according to Directive 2006/42/EC of the European Parliament and the Council of 17 May 2006

Manufacturer:  
KIESELMANN GmbH  
Paul-Kieselmann-Str. 4-10  
D-75438 Knittlingen

We declare that the following pressure equipment

<u>Designation</u>	<u>Function</u>
Pneumatic Linear actuator	pneumatically operation of valves
Pneumatic Quarter-turn actuator	pneumatically operation of valves
Butterfly Valve (pneumatically operated)	Separation of medium flow
Ball Valve (pneumatically operated)	Separation of medium flow
Single seat Valve (pneumatically operated)	Separation of medium flow
Changeover Valve (pneumatically operated)	Separation of medium flow
Double-Seat mixproof Valve (pneumatically operated)	Separation of medium flow
Control Valve (pneumatically operated)	Regulation of medium flow
Throttling Valve (pneumatically operated)	Regulation of medium flow
Tank Outlet Valve (pneumatically operated)	Separation of medium flow
Sampling Valve (pneumatically operated)	Separation of medium flow

complies with the definition of an „incomplete machine“ according to Article 2 of the European Machinery Directive 2006/42/EG, when fitted in or merged with other machines or incomplete machines which also comply with the provision of the Directive.

Applied harmonized standards:

Directive 2014/68/EU  
EN ISO 12100

Person responsible for documentation:

Achim Kauselmann  
Documentation / Development  
KIESELMANN GmbH

Knittlingen, 10.10.2020

  
i.V. Uwe Heisswolf  
Head of Development

  
**KIESELMANN**  
FLUID PROCESS GROUP







**KIESELMANN GmbH**

Paul-Kieselmann-Str. 4-10  
D - 75438 Knittlingen

☎ +49(0) 7043 371-0 • 📠 +49(0) 7043 371-125  
[www.kieselmann.de](http://www.kieselmann.de) • [info@kieselmann.de](mailto:info@kieselmann.de)

---

Copyright: © KIESELMANN FLUID PROCESS GROUP