



KIESELMANN

FLUID PROCESS GROUP

Translation of the original

Operating Instructions

Double seat valves

Type 564x

DN 40- DN 100

OD 1½ Inch - OD 4 Inch

Seal material: k-flex



KIESELMANN GmbH

Paul-Kieselmann-Str. 4-10
D - 75438 Knittlingen

 +49(0) 7043 371-0 •  +49(0) 7043 371-125
www.kieselmann.de • info@kieselmann.de

Copyright: © KIESELMANN FLUID PROCESS GROUP

Table of contents

1	General informations	4
1.1	Informations for your safety	4
1.2	Marking of security instructions	4
1.3	General designated use	4
1.4	Personnel	4
1.5	Modifications, spare parts, accessories	5
1.6	General instructions	5
2	Safety instructions	6
2.1	Intended use	6
2.2	General notes	6
2.3	General safety instructions	6
3	Delivery, transport and storage	8
3.1	Delivery	8
3.2	Transport	8
3.3	Storage	8
4	Specification	9
4.1	Modular system	9
5	Function and operation	10
5.1	Description of function	10
5.2	Control system and position indicator	10
5.3	Pneumatic valve activation	11
6	Commissioning, service and maintenance	12
6.1	Commissioning	12
6.1.1	Installation instructions	12
6.1.2	General welding guidelines	12
6.1.3	ATEX - Guidelines	12
6.2	Service	13
6.2.1	Maintenance table	13
6.3	Cleaning	13
7	Technical data	14
7.1	Double seat valve Type 564x	14
7.2	KV - value	14
7.3	Torques	15
7.4	Cleaning flow rate	15
8	Disassembly and assembly	16
8.1	Disassembly	16
8.1.1	Assembly valve insert VE	17
8.1.2	Replacement wear parts	17
8.2	Assembly	20
8.2.1	Seals (D4)	22
8.2.2	Shaft sealing	23
9	Drawings and dimensions	25
9.1	Double seat valve	25
9.1.1	Lantern with rinsing connection	28
9.1.2	Control units	28
9.1.3	Dimensions	29
10	Wearing parts	30
10.1	Double seat valve Type 564x	30
11	Classification	36
11.1	Structure of Order Number	36
12	Appendix	38
12.1	Declaration of incorporation	38

1 General informations

1.1 Informations for your safety

We are pleased that you have decided for a high-class KIESELMANN product. With correct application and adequate maintenance, our products provide long time and reliable operation.





Before installation and initiation, please carefully read this instruction manual and the security advices contained in it. This guarantees reliable and safe operation of this product and your plant respectively. Please note that an incorrect application of the process components may lead to great material damages and personal injury.

In case of damages caused by non observance of this instruction manual, incorrect initiation, handling or external interference, guarantee and warranty will lapse!

Our products are produced, mounted and tested with high diligence. However, if there is still a reason for complaint, we will naturally try to give you entire satisfaction within the scope of our warranty. We will be at your disposal also after expiration of the warranty. In addition, you will also find all necessary instructions and spare part data for maintenance in this instruction manual. If you don't want to carry out the maintenance by yourself, our KIESELMANN - service team will naturally be at your disposal.

1.2 Marking of security instructions

Hints are available in the chapter "safety instructions" or directly before the respective operation instruction. The hints are highlighted with a danger symbol and a signal word. Texts beside these symbols have to be read and adhered to by all means. Please continue with the text and with the handling at the valve only afterwards.

Symbol	Signal word	Meaning
	DANGER	Imminent danger which will result severe personal injury or death.
	WARNING	Imminent danger which may result severe personal injury or death.
	CAUTION	Dangerous situation which may cause slight personal injury or material damages.
	NOTICE	An harmful situation which may result in damages of the product itself or of adjacent vicinity.
	INFORMATION	Marks application hints and other information which is particularly useful.

1.3 General designated use

The fitting is designed exclusively for the purposes described below. Using the fitting for purposes other than those mentioned is considered contrary to its designated use. KIESELMANN cannot be held liable for any damage resulting from such use. The risk of such misuse lies entirely with the user. The prerequisite for the reliable and safe operation of the fitting is proper transportation and storage as well as competent installation and assembly. Operating the fitting within the limits of its designated use also involves observing the operating, inspection and maintenance instructions.

1.4 Personnel

Personnel entrusted with the operation and maintenance of the tank safety system must have the suitable qualification to carry out their tasks. They must be informed about possible dangers and must understand and observe the safety instructions given in the relevant manual. Only allow qualified personnel to make electrical connections.

1.5 Modifications, spare parts, accessories

Unauthorized modifications, additions or conversions which affect the safety of the fitting are not permitted. Safety devices must not be bypassed, removed or made inactive. Only use original spare parts and accessories recommended by the manufacturer.

1.6 General instructions

The user is obliged to operate the fitting only when it is in good working order. In addition to the instructions given in the operating manual, please observe the relevant accident prevention regulations, generally accepted safety regulations, regulations effective in the country of installation, working and safety instructions effective in the user's plant.

2 Safety instructions

2.1 Intended use

Based upon its functions, the double seat valve is suitable for use in the food and beverages, in pharmaceutical, biotechnological and chemical industries. It is used mainly in combinations with several other double seat valves for the purpose of emptying and filling containers with the possibility of connecting several pipes to one tank.

2.2 General notes



NOTICE - observe the operating instructions

To avoid danger and damage, the fitting must be used in accordance with the safety instructions and technical data contained in the operating instructions.



NOTICE

All data are in line with the current state of development. Subject to change as a result of technical progress.

2.3 General safety instructions



⚠ WARNING

Risk of injury by moving parts

Do not grab into the valve when the actuator is pressurized. Limbs can be crushing or amputating.

- Remove the control air line before dismantling.
- Ensure that the actuator is unpressurized.



⚠ WARNING

Risk of injury by outflowing medium

Dismantling the valve or valve assemblies from the plant can cause injuries.

- Media flowing through the leakage drain outlet are to be drained off without splashing into a discharge arrangement.
- Carry the disassembling only if when the plant has been rendered pressure-less and free of liquid and gas.



⚠ WARNING

Risk of injury by pre-stressed pressure spring.

The actuator is spring-loaded. When disassembling the actuator, components that jump out may cause injuries.

- For dismantling please observe the separate assembly instructions.
- We recommend having the manufacturer do the maintenance work required for the actuation.



⚠ WARNING

Use in EX areas

If the valve or the plant is operated in a potentially explosive atmosphere, the valid directive and the installation instructions in this operating manual must be observed.

**⚠ CAUTION**

When mounting the clamps, the max. torque must not be exceeded.
(see technical data)

**⚠ CAUTION**

To avoid air leaking, only use pneumatic connection parts that have an O-ring seal facing the even surface.

**⚠ CAUTION**

Before starting the system, the entire pipeline system must be thoroughly cleaned.

**⚠ CAUTION**

Steps should be taken to ensure that no external forces are exerted on the fitting.

3 Delivery, transport and storage

3.1 Delivery

- Immediately after receipt check the delivery for completeness and transport damages.
- Remove the packaging from the product.
- Retain packaging material, or expose of according to local regulations.

3.2 Transport



⚠ CAUTION

Risk of injury and damage to the product

During the transport the generally acknowledged rules of technology, the national accident prevention regulations and company internal work and safety regulations must be observed.

3.3 Storage



NOTICE

Damage to the product due to improper storage!

Observe storage instructions
avoid a prolonged storage



INFORMATION













Recommendation for longer storage

We recommend regularly checking the product and the prevailing storage conditions during long storage times.

- To avoid damage to seals and bearings,
 - products up to DN 125 / OD 5 inch should be stored horizontally for maximum 6 months.
 - products larger than DN 125 / 5 inch, should be stored in the upright position with the actuator on top.
- Don't store any objects on the products.
- Protect the products for wetness, dust and dirt.
- The product should be stored in a dry and well ventilated room at a constant temperature (optimal indoor temperature: 25 C ±5 ; indoor humidity data 70% ±5%).
- Protect seals, bearings and plastic parts for UV light and ozone.

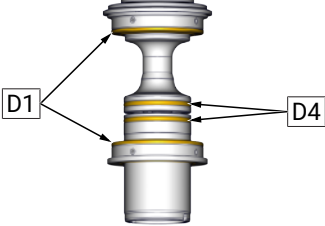
4 Specification

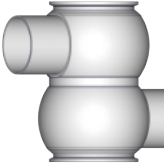
4.1 Modular system

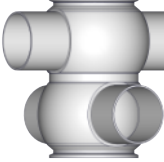
KI-Top control head		feedback unit		
				
Stainless steel hood	Transparent hood	Feedback unit with finger guard (E)		
Actuator pneumatic				
				
ø109	ø128	ø135	ø160	ø230
Valve insert				
				
Sealing material				
<u>Shaft seal D1</u> k-flex EPDM HNBR FKM				<u>Valve disc-seal ring D4</u> k-flex
Valve housing				
				
Type 56x1 (SS-S)		Type 56x2 (S-S)		
				
Type 56x3 (S-SS)		Type 56x4 (SS-SS)		

5 Function and operation

5.1 Description of function

The valve opens from the top down by means of control air and closes bottom to top by means of spring tension without loss of product. In the closed setting, mix-proof separation of the media flowing in the upper and lower valve chambers is ensured by two independently closed valve plates. Any leaks occurring due to damaged valve plate seals are drained to the exterior without pressure via the leakage discharge (L).

5.2 Control system and position indicator



Feedback unit -optional-

Optionally, modular valve control head systems can be installed to the actuator for reading and actuating valve positions. The standard version is a closed system with SPS or ASI-bus switch-on electronics, and integrated 3/2-way solenoid valves. For tough operating conditions we recommend employing a high-grade steel cover.



Feedback unit with finger guard -optional-

For the acquisition of the valve positions over inductive initiators (Sensors), a feedback unit is mounted on the actuation. The enquiry takes place over the position of the piston rod.

5.3 Pneumatic valve activation

Valve functions	Pneum. activation via control head with solenoid valves (MV)	Pneum. activation via external Solenoid valves (MV external)
main lift valve "OPEN"	Control supply air P - MV1 - P1/LA1	Control supply air ext.MV1 - LA1
main lift valve "CLOSE"	Ventilation P1/LA1 - MV1 - R valve is closing by spring	Ventilation LA1 - ext.MV1 valve is closing by spring
lifting lower seat	OPEN = control air feed P - MV2 - P2/LA2	OPEN = control air feed ext.MV2 - P - LA2
	CLOSE = de-aeration P2/LA2 - MV2 - R valve is closing by spring	CLOSE = de-aeration LA2 - P - ext.MV2 valve is closing by spring
Lifting upper seat	OPEN = control air feed P - MV3 - P3/LA3	OPEN = control air feed ext.MV3 - LA3
	CLOSE = de-aeration P3/LA3 - MV3 - R valve is closing by spring	CLOSE = de-aeration LA3 - ext.MV3 valve is closing by spring

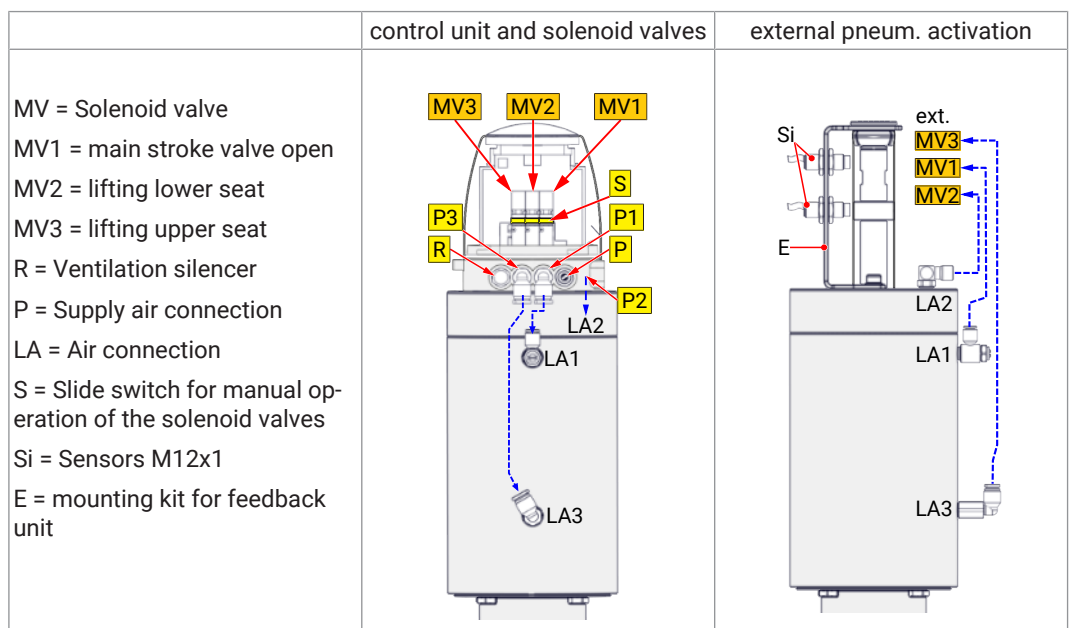

6 Commissioning, service and maintenance

6.1 Commissioning



NOTICE

Checking the solenoid valves in the control head

Before using the valve for the first time, the function of the solenoid valves in the control head must be checked.

- Remove the hood on control head.
- Connect the supply air to the control head
- Check the valve functions using the slide switches on the solenoid valve

⇒ Please also read the [documentation for control heads!](#)

6.1.1 Installation instructions

Fitting position

The valve must be installed vertically with the actuator at the upwards. Liquid must be able to flow freely from the valve housing.

6.1.2 General welding guidelines

Sealing elements integrated in weld components must generally be removed prior to welding. To prevent damage, welding should be undertaken by certified personnel (EN ISO 9606-1). Use the TIG (Tungsten Inert Gas) welding process.



CAUTION

Damage and injuries due to high temperature supply

To avoid a distortion of the components, all welding parts must be welded to stress-relieved. Allow all components to cool before assembling.



NOTICE

Damage due to impurities

Impurities can cause damage to the seals and seals area.

Clean inside areas prior to assembly.

6.1.3 ATEX - Guidelines

For valves or plants/installations that are operated in the ATEX area, sufficient bonding (grounding) must be ensured (see valid ATEX Guidelines EG).

6.2 Service



RECOMMENDATION

Replacement of seals

To achieve optimal maintenance cycles, the following points must be observed!

- When replacement of seals, all product-contacting seals should be replaced.
- Only original spare parts may be installed.

Maintenance interval

The maintenance intervals depend on the operating conditions "temperature, temperature-intervals, medium, cleaning medium, pressure and opening frequency". We recommend replacing the seals 1-year cycle. The user, however should establish appropriate maintenance intervals according to the condition of the seals.

Lubricant recommendation

	EPDM; HNBR; NBR; FKM; k-flex	- Klüber Paraliq GTE703*
	Silicone	- Klüber Sintheso pro AA2*
	Thread	- Interflon Food*
*) It is only permitted to use approved lubricants, if the respective fitting is used for the production of food or drink. Please observe the relevant safety data sheets of the manufacturers of lubricants.		

Maintenance - Lift actuator

The actuator is maintenance-free and non-removable.

6.2.1 Maintenance table

	Annually	Additional information
6.2 Service	1	

1 - Maintenance personnel

6.3 Cleaning

Cleaning of the housing is performed with the pipe cleaning system. As part of the cleaning program, the leakage chamber and the drain pipe can be cleaned by cycling the valve discs. The valve disc shaft is also cleaned when the upper valve disc is cycled.

Alternatively, the leakage chamber and the shaft of the upper valve disc can be cleaned by means of the external rinsing connection. For cleaning the shaft, the upper valve disc has to be lifted.

7 Technical data

7.1 Double seat valve Type 564x

Model	Double seat valve	
Size	DIN: DN40 - DN100 Inch: OD1¼ - OD4	
Connection type	Weld-on end EN 10357	
Temperature range	Ambient temperature: (air)	+4°C to +45°C
	Operating temperature: (depends on medium)	-5°C to +100°C
	Sterilisation temperature: (SIP 30 min)	EPDM +140°C HNBR +100°C k-flex +140°C FKM +100°C
Operating pressure	10 bar	
Pressure resistance	40 bar	
Leakage rate	A (EN 12266-1)	
Control air	Control air pressure:	5,5 - 8,0 bar
	Control air quality:	ISO 8573-1:2010 [3:(≤5 µm):4:4]
Material (in contact with product)	Stainless steel:	1.4404 / AISI 316L
	Surface:	Ra ≤ 0,8µm, e-polished
	Sealing material:	EPDM (FDA) HNBR (FDA) k-flex (FDA) FKM

7.2 KV - value

	ND	25	40	50	65	80	100	125	150
	Inch	1	1½	2	2½	3	4	5	6
flow direction:		[m³/h]							
transition-flow at top↔		26	50	95	150	240	380	580	940
transition-flow at bottom ↔		26	55	100	155	250	390	590	940
from bottom to top ↑		16	26	45	72	98	155	245	370
from top to bottom ↓		16	24	43	67	93	150	240	330

7.3 Torques

Torque: clamp coupling

	DN	25	40	50	65	80	100
	Inch	1	1½	2	2½	3	4
Torque [Nm]		15	15	15	25	25	55

7.4 Cleaning flow rate

Cleaning parameters for the leakage chamber

Cleaning step	valve disc lifting	DIN Inch	25 1	40 1½	50 2	65 2½	80 3	100 4	125 5	150 6
Pre-Rinse	-	lifting upper seat	0,97	1,10	1,1	1,38	1,66	2,08	2,50	4,02
Lye 80°C	3 x 5 sec.									
Intermediate rinse	2 x 5 sec.		(l/s bei 3bar)							
Acid	3 x 5 sec.	lifting lower seat	0,54	0,69	0,69	0,83	0,83	1,25	1,66	2,50
Final rinse	2 x 5 sec.									

8 Disassembly and assembly

8.1 Disassembly









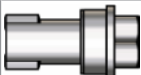
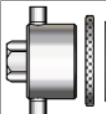

NOTICE

All threaded joint have right-hand thread.

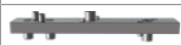
Unscrew and remove control air, steam resp. cleaning lines and electrical lines, complete feedback unit or control head.

Assembly Tools

Mounting tools sets:		DN40 - DN65	5670 065 100-000	●		
		DN80 - DN100	5670 100 100-000		●	
		DN125 - DN150	5670 150 100-000			●
ST1		Socket	DN40 - DN65 DN80 - DN150	5620 065 131-130 5620 100 131-130	●	● ●
ST2		Socket + guide bush (POM) + O-rings	DN40 - DN65 DN80 - DN100 DN125 - DN150	5670 080 105-000 5670 100 105-000 5670 150 105-000	● ●	● ●
ST3		Eccentric socket	DN40 - DN65 DN80 - DN150	5620 065 134-130 5620 100 134-130	●	● ●
ST4		Centring ring	DN40/50 DN65 DN80 DN100 DN125 DN150	5620 050 025-020 5620 065 025-020 5620 080 025-020 5620 100 025-020 5620 125 025-020 5620 150 025-020	●	● ● ● ● ● ●
T10		Joint-pin wrench	DN40 - DN65 DN80 - DN150	5620 065 015-000 5620 150 015-000	●	● ●
ST15		Mounting plate	DN40 - DN65 DN80 - DN100 DN125 - DN150	5620 065 121-020 5620 100 121-020 5620 150 121-020	●	● ● ●

Pos.	Figure	Designation		Article number
T1		Combination wrench-Set	SW 8 - SW 24	-
T4		Soft-head hammer	-	-
T40		Socket box	SW8 - SW36	-
ST16		Mounting wrench	DN 40 - 150	5670150126-020

8.1.1 Assembly valve insert VE

- Unscrew the upper retaining clamp (VK).
- Connect compressed air to LA1 and pressurize the actuator with air.
 - The valve insert lift up of the valve housing (VG).
- Pinch a rubber (Z) between the Lantern (15) and the housing (VG).
- Disconnect compressed air at LA1 and depressurize the drive. - The valve piston move in.
- Remove the complete valve insert with the upper shaft seal (D1) from the housing (VG).
- Unscrew the lower retaining clamp (VK).
- Remove the housing bottom (1) with the lower shaft seal (D1) from the housing (VG).

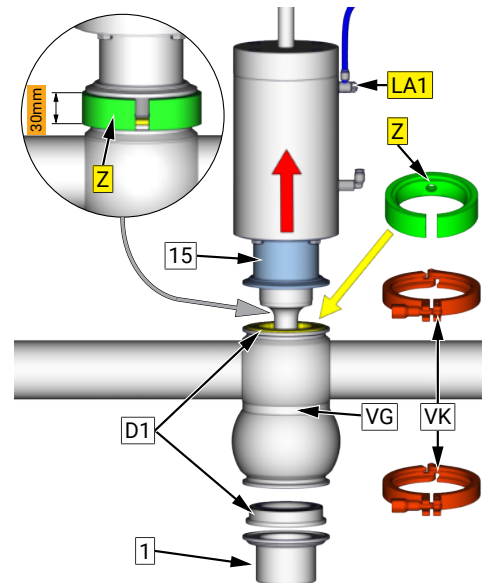

8.1.2 Replacement wear parts

Disassembly

- Unscrew nut (11) and remove disc (10).
- Dismount the upper piston (6) from the upper piston (7) in direction X.
- Remove the split washer (13).

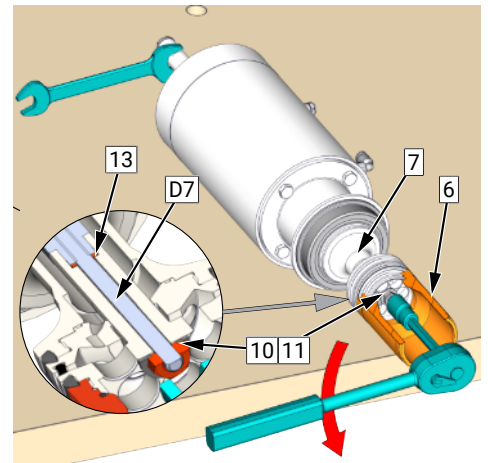

- Remove the O-ring (D5).
- Unscrew the hexagon screws (14).
- Push the lantern (15) in direction 'X' until the hole (B1) is freely visible.

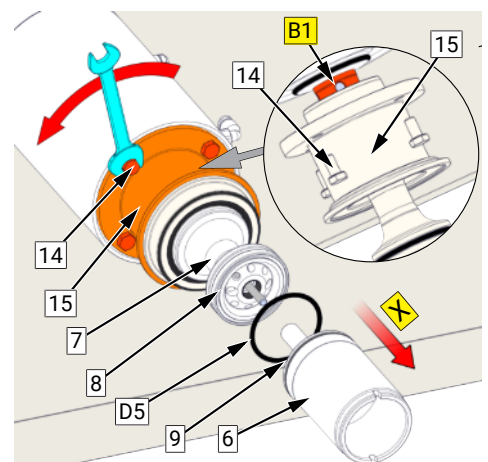

- Unscrew the upper piston (7) with the mounting plate ST15 from piston rod (3).
Counter with the pin wrench T10 at the hole (B1).

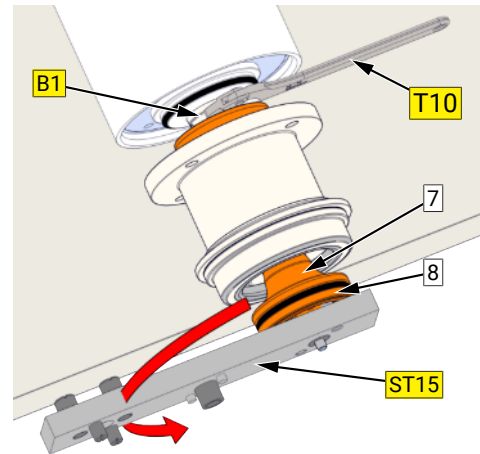

- $\geq 40 / 1\frac{1}{2}$ (valves with divided pistons):
Should be untighten the piston plate (8) before piston (7), then unscrew the piston (7) with the eccentric ST3 and a ratchet.

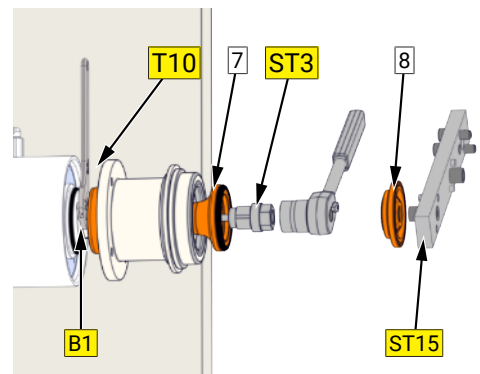

- Push the lantern (15) and the upper shaft seal (D1) from the piston (7).
- Dismount the valve lift stop (16).
- Remove seals: Pos. (D1); (D8); (D9); (D10).

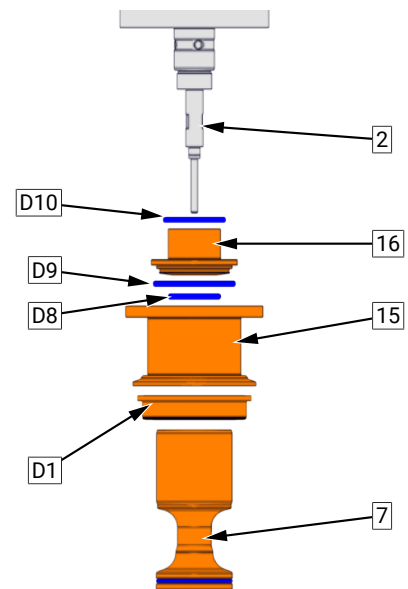

8.1.2.1 Assembly seal (D4)

Remove seals (D4) from pair of piston (7) / (8) and pair of piston (6) / (9).

- Clamp the mounting plate ST15 into the vice.
- Put the piston (6) resp. (7) on the mounting plate in the fittingly pins.
- Unscrew the piston (6) from the lower piston plate (9) with the socket ST2 and the mating reducing bush.
- Unscrew the piston (7) from the lower piston plate (8) with the socket ST1.

- Remove seals (D4).

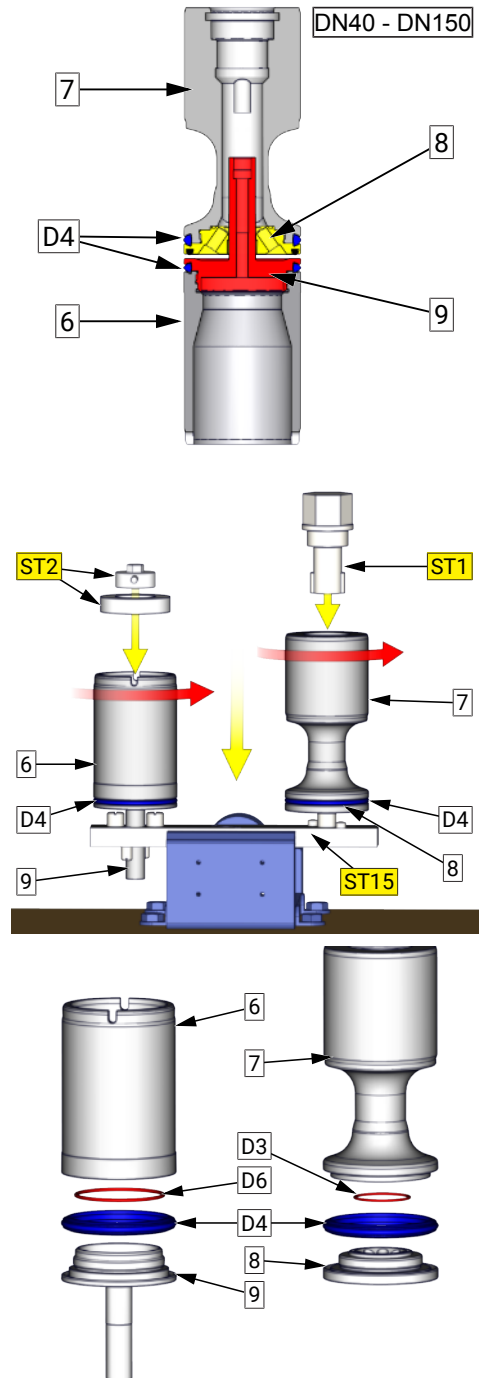

8.2 Assembly

Assemble in reverse order.

Thoroughly clean and slightly lubricate mounting areas and running surfaces.



NOTICE

During assembly, the following points must be observed!

Folgen

- Always replace the hexagon lock nut (11) by a new one after unscrewing.
- Carefully fit in the complete valve insert into the casing. When fitting the valve insert and running surfaces onto the piston, do not damage.
- - Check valve functions by manually activating the 3/2-way solenoid valves after assembly!

Mounting clamp coupling (VK)

- For mounting the clamp coupling (VK), please note that it continuously fits form locking to the inclinations of the casing and the lantern/casing bottom.
- The centring of the retaining clamp (VK) during tightening can be accomplished with a slight beat (please use a soft-head hammer) on the extent of the retaining clamp (VK).
- Beim Anziehen der Verschlussklammer (VK) muss das Drehmoment und die Spaltgröße 'S' (When tightening the clamp coupling (VK), please pay attention to the turning moment and the gap size 'S' ($\leq 0,4\text{mm}$) between casing and lantern/casing bottom.

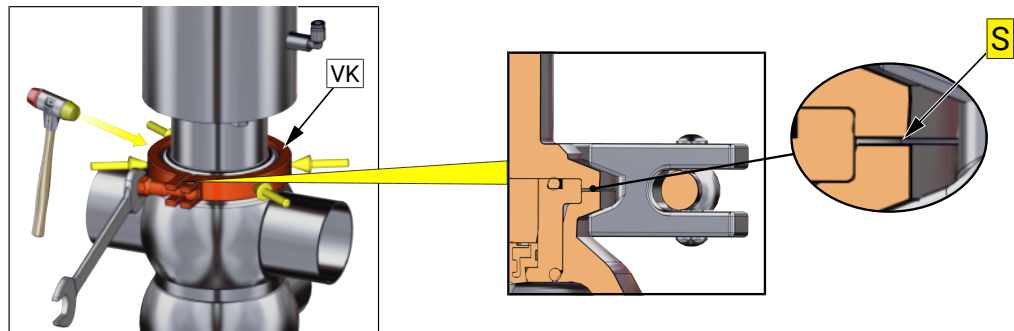

Mounting seal (D4) for divided piston

Pair of piston lower = Piston (6) and piston plate (9)

Pair of piston upper = Piston (7) and piston plate (8)

- Remove O-rings (D3) and (D6).
- Screw together the pair of piston (7) / (8) and (6) / (9) without the seal (D4) to the metal limit stop by hand.
- Make a colored mark at the piston surfaces.
- After then, unscrew the pairs of piston again.

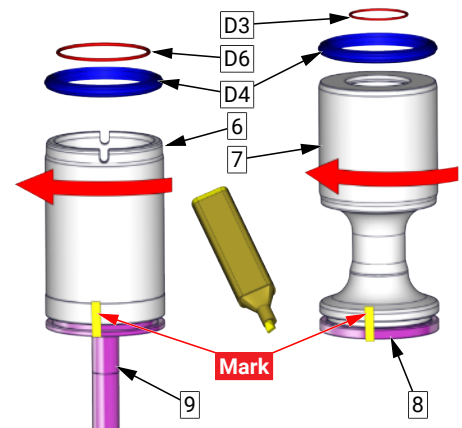

- Slide the seal (D4) onto the pistons.
- Screw together the pair of piston by hand again.
- Clamp the mounting plate ST15 into the vice.
- Fix the lower pair of piston (6) / (9) with the piston plate (9) on the mounting plate M6.
- Position the eccentric ring ST4 on seal (D4).
- Screw up the piston (6) with the socket ST2 and a ratchet to the final limit mark.

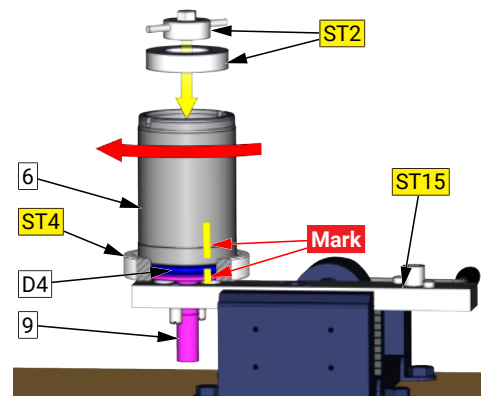

- Clamp the socket ST1 into the vice at the hexagon flat.
- Fix the upper pair of piston (7) / (8) with the piston (7) of the socket ST1.
- Position the eccentric ring ST4 on seal (D4).
- Screw up the piston plate (8) to the final limit mark. Use the mounting plate ST15.

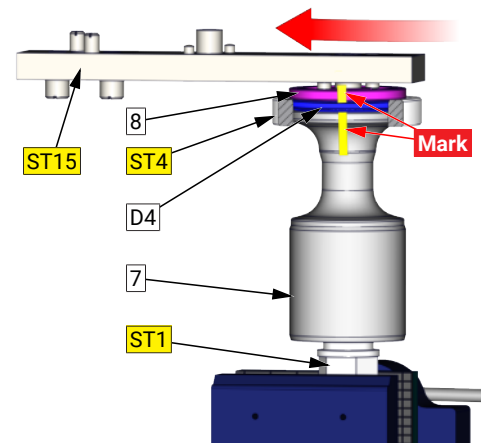

8.2.1 Seals (D4)

Seal D4 - Elastomer

Model Seal (D4)	Piston (6) and (7)		Pair of piston upper (7) and (8) Pair of piston lower (6) and (9)	
	DN 25 / OD 1		DN 40-125 / OD 1½-5	DN 150 / OD 6
	Piston <u>not</u> divided ¹		Piston divided	Piston divided
O-ring EPDM	x	x ²	x	
O-ring HNBR	x	x ²	x	
c) Seal with support ring EPDM	-	x	-	
d) Seal with support ring HNBR	-	x	-	

1. According their construction from valve size DN 25/1", the pistons (6) and (7) are not divided.
2. O-ring version till 05/2016 thereafter seal EPDM (D4)c / HNBR (D4)d

Seal - Model	
D4 = Seal D4-1 = Seal jacket (seal material) D4-2 = Backup ring	

Seal D4 - k-flex

	Nominal size	Article number	Material
k-flex - Seal (D4)	DN40-DN50	5621 050 010-114	k-flex
consists of	DN65-DN100	5621 xxx 010-114	
Ring quartered (D4-3)	DN40-DN50 DN65-DN100	5621 050 011-020 5621 xxx 011-020	1.4301 / AISI304
O-ring (D4-2)	DN40-DN50 DN65 DN80 DN100	2304 050 026-159 2304 060 026-159 2304 076 026-159 2304 095 026-159	EPDM
k-flex Seal (D4-1)	DN40-DN50 DN65-DN100	5621 050 012-114 5621 xxx 012-114	k-flex

(xxx = nominal diameter e.g. 050 for nominal diameter DN50)

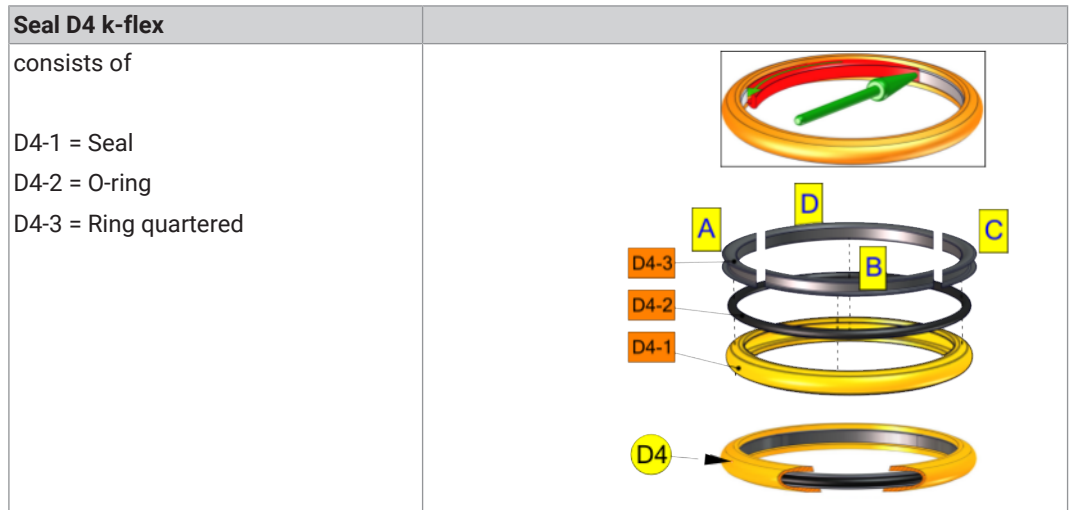

8.2.2 Shaft sealing

Shaft sealing - k-flex

Shaft sealing	Nominal diameter	Item number	Material:
k-flex - Shaft seal (D1)	DN25-DN100	5622 xxx 010-114	k-flex
consists of			
k-flex Seal (D-1)	DN50-DN100	5622 xxx 025-114	k-flex
Circlip (D-2)	DN50-DN100	5622 xxx 029-031	1.4310 / AISI301
Half-shell (D-3)	DN50-DN100	5622 xxx 027-020	1.4301 / AISI304
Insert (D-4)	DN25; DN50-DN100	5622 xxx 026-020	1.4301 / AISI304
Sleeves (D-5)	-	5622 100 028-020	1.4301 / AISI304

(xxx = nominal diameter e.g. 050 for nominal diameter DN50 ; DN25 only Double seat valves)

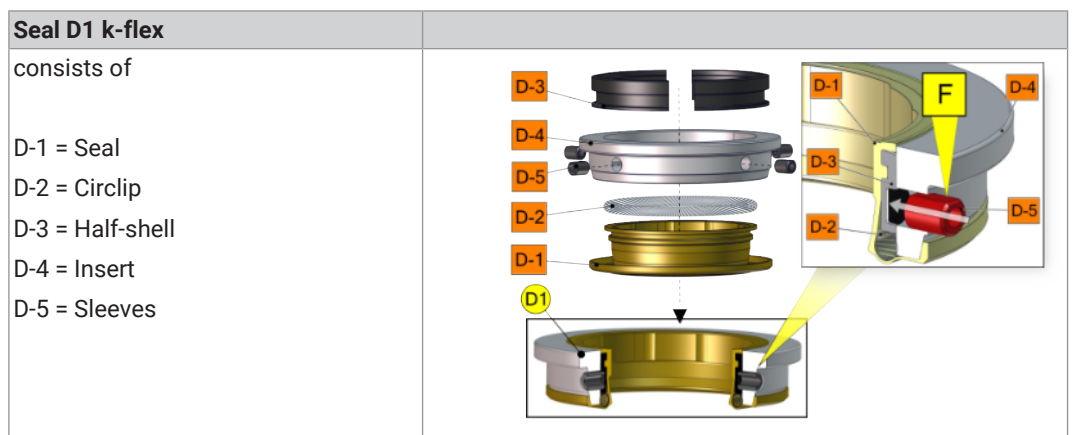

Assembly shaft seal k-flex D1

- Install the annular spring into the k-flex seal.
- **NOTICE** The joining edges of the half shells need to be installed in an offset position to the bore-holes in the insert.
- Place both half-shells around the k-flex seal and then install the into the insert.
- The sleeves should be mounted in the insert.
- **NOTICE** The ground surface of the sleeves need to be mounted parallel to the edge (F) of the half-shell.
- Push the shaft seal onto the assembly mandrill.
- Place the assembly mandrel and the shaft seal onto the piston.
- Push the shaft seal toward onto the piston.

- **NOTICE** To dismantle the sleeves, an M4 screw is screwed into the sleeves and then used to pull the sleeves from the insert.

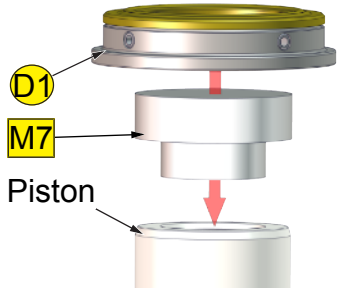
Assembly mandrel M7	5620 xxx 027-062
<p>We recommend using the assembly mandrill for the assembly.</p> <p>(xxx = nominal diameter e.g. 050 for nominal diameter DN50)</p>	 <p>The diagram illustrates the assembly process for the assembly mandrel M7. It shows a cross-section of the assembly with three main components: a top cap with a yellow top surface, a middle sleeve, and a bottom piston. A red arrow points downwards from the top cap, indicating the direction of assembly. Labels with arrows point to the top cap (D1), the sleeve (M7), and the piston (Piston).</p>

9 Drawings and dimensions

9.1 Double seat valve

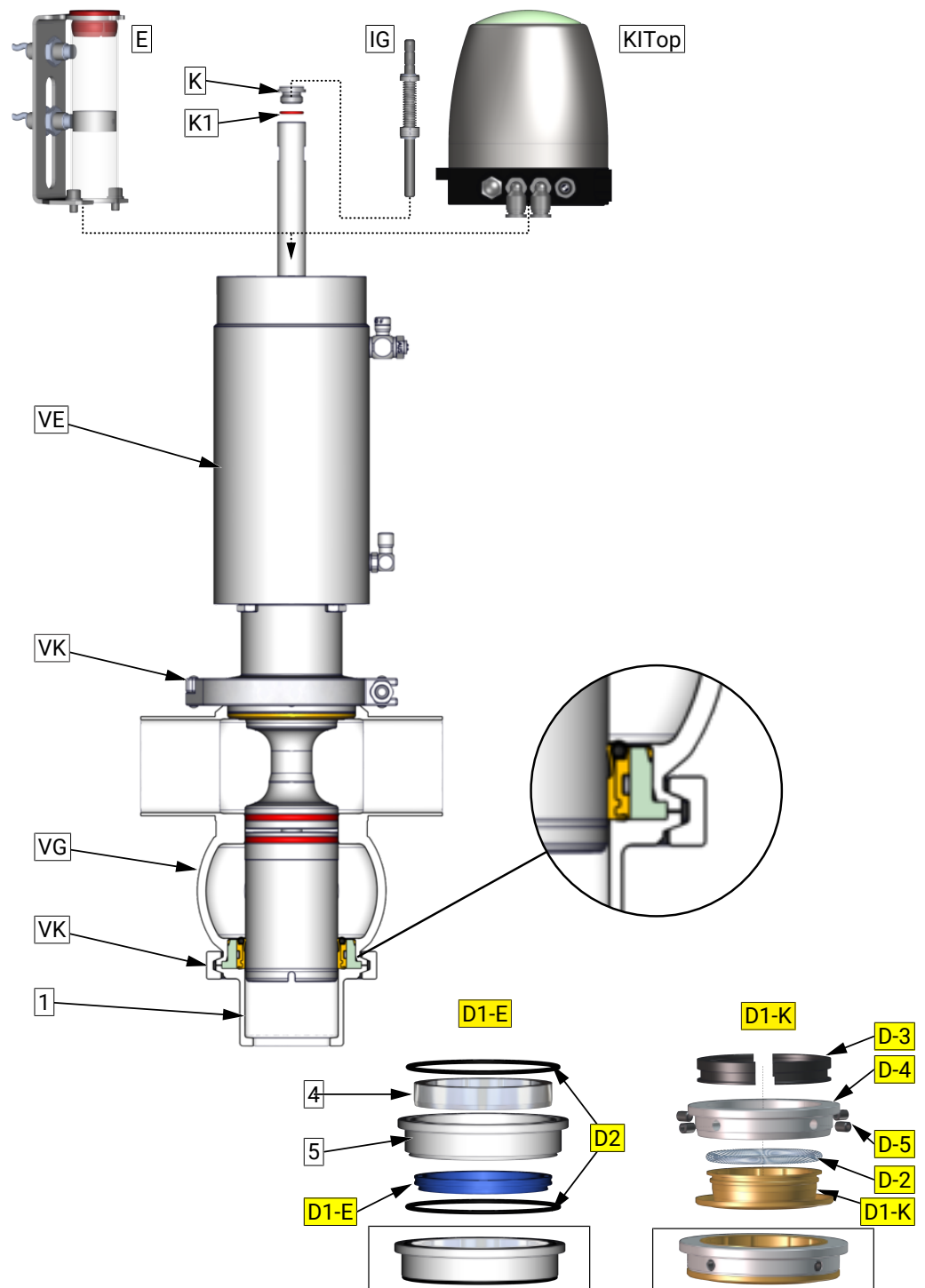

1	Housing bottom	4	Bearing bush
5	Housing insert	D1-E	Shaft seal Elastomer
D1-K	Shaft seal k-flex	D2	O-ring
E	feedback unit	IG	Pulse generator
K	Cap	K1	O-ring
KITop	Control Head	VE	Valve insert
VG	Valve housing	VK	Locking clip
D-3	Half-shell	D-2	Shaft seal k-flex
D-4	Insert	D-5	Sleeves

Valve insert VE - k-flex

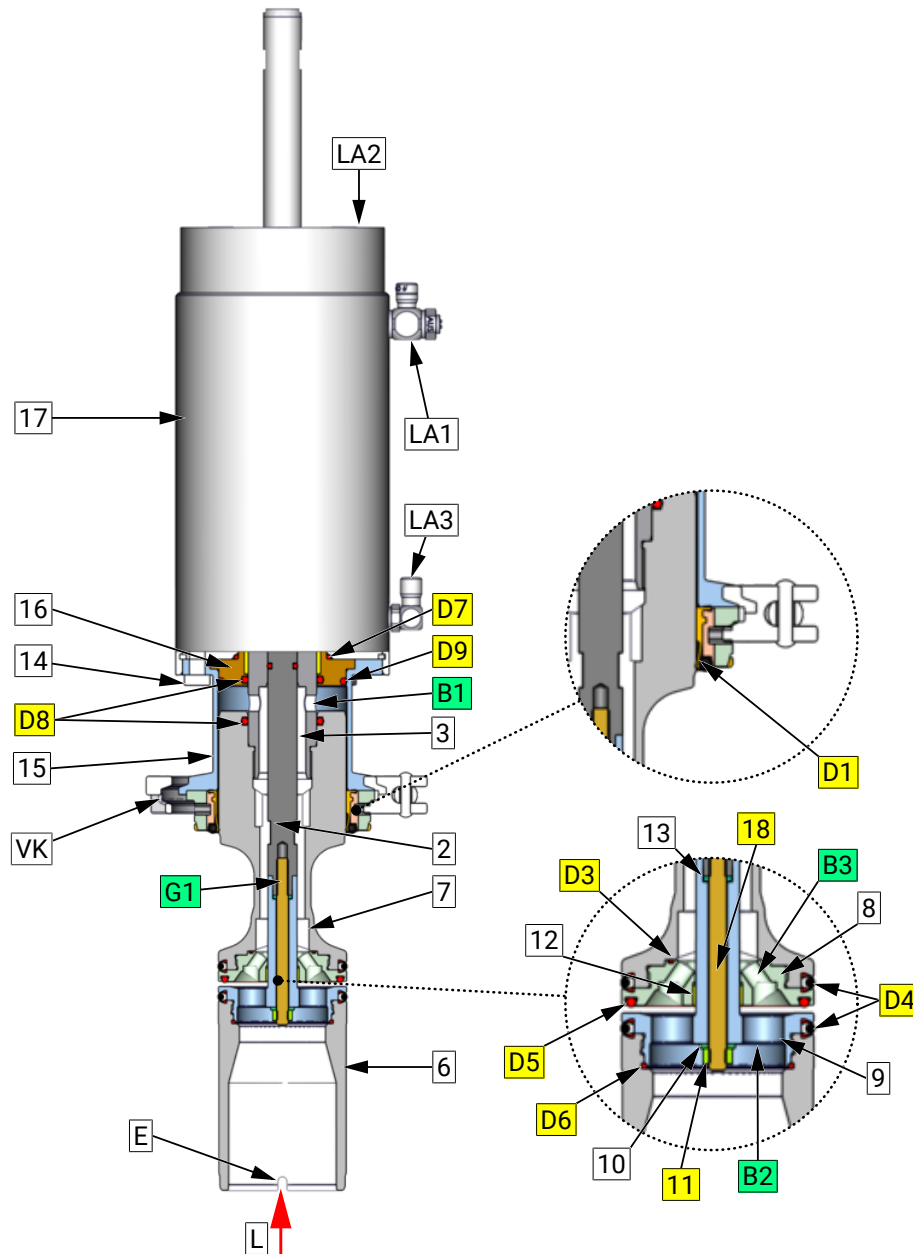

1 -	2 Spindle
3 Piston rod	4 -
5 -	6 Piston lower
7 Piston upper	8 Piston plate upper
9 Piston plate lower	10 Washer
11 Hexagon nut	12 Slide bearing
13 Split washer	14 Screw
15 Lantern	16 Valve lift stop
17 pneum. Drive	18 Headless pin
B1 Thread connection	B2 Mounting hole
B3 Mounting hole	D1 Shaft seal
D2 -	D3 O-ring
D4 Seal	D5 O-ring
D6 O-ring	D7 O-ring
D8 O-ring	D9 O-ring
E Groove	G1 Thread connection
LA1 Air connection	LA2 Air connection
LA3 Air connection	L Leakage drain

Valve insert VE - Elastomer / k-flex

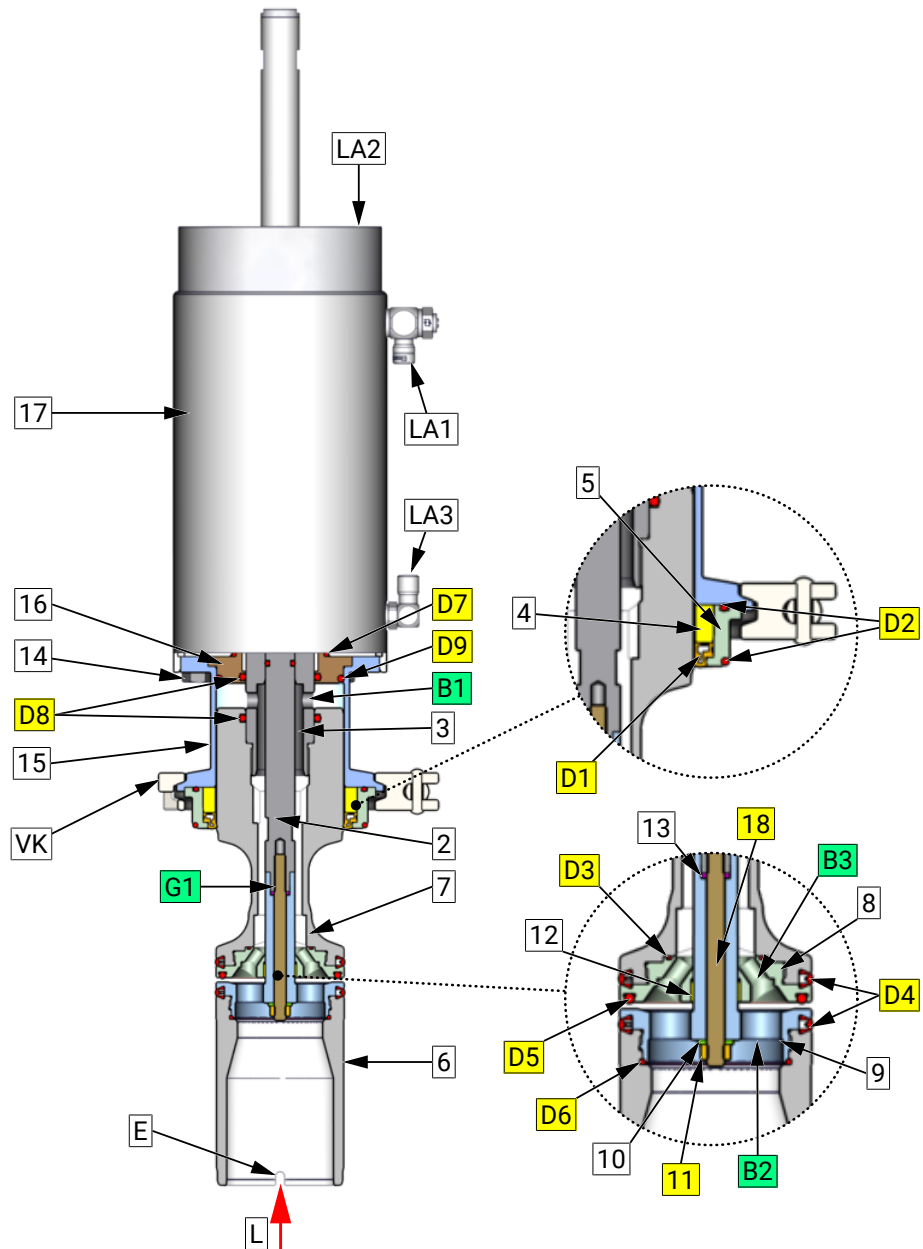

2 Spindle	3 Piston rod
4 Bearing bush	5 Housing insert
6 Piston lower	7 Piston upper
8 Piston plate upper	9 Piston plate lower
10 Washer	11 Hexagon nut
12 Slide bearing	13 Split washer
14 Screw	15 Lantern
16 Valve lift stop	17 pneum. Drive
18 Headless pin	B1 Mounting hole
B2 Mounting hole	B3 Mounting hole
D1 Shaft seal	D2 O-ring
D3 O-ring	D4 Seal
D5 O-ring	D6 O-ring
D7 O-ring	D8 O-ring
D9 O-ring	E Groove
G1 Thread connection	LA1 Air connection
LA2 Air connection	LA3 Air connection
L Leakage drain	

9.1.1 Lantern with rinsing connection

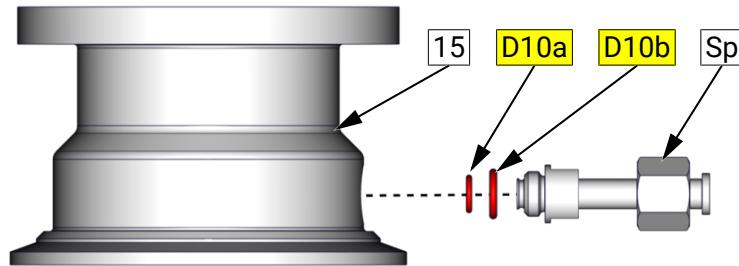

15 Lantern	D10a O-ring
D10b O-ring	Sp Rinsing connection

9.1.2 Control units

Control head KI-TOP

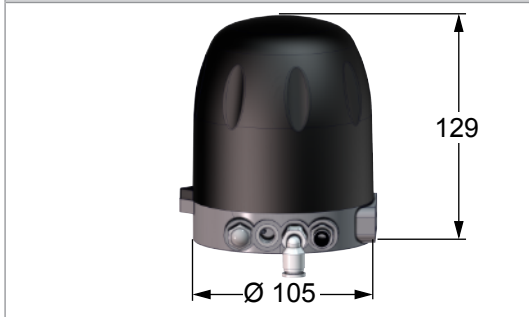

Feedback unit with finger guard (E)

- E1 = Cap
- E2 = Angle bracket
- E3 = Shell transparent
- E4 = Set collar
- E5 = Headless pin
- E6 = Allen screw
- E7 = FLaT washer

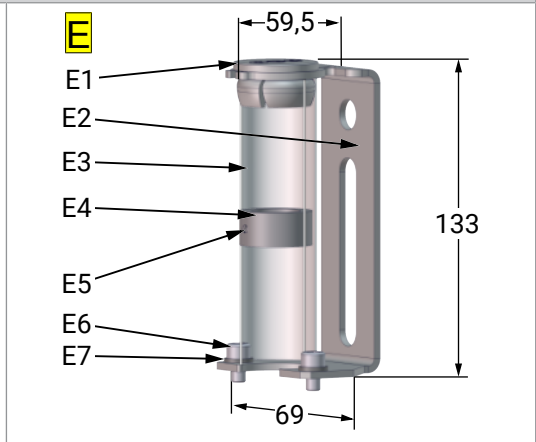

Pulse generator (IG) - Double seat mixproof valve

- IG1 = Threaded rod
- IG2 = Locking ring / Nut
- IG3 = Washer
- IG4 = Magnet
- IG5 = Spring
- ZB = Center hole (Mounting position = TOP)

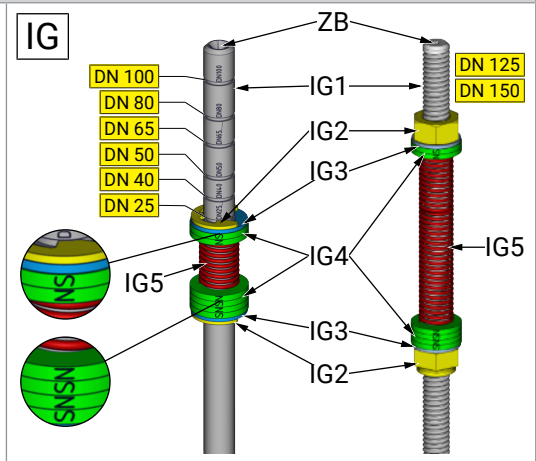

9.1.3 Dimensions

	DIN	25	40	50	65	80	100
	Inch	1	1½	2	2½	3	4
D1 / D2	DIN Inch	Ø29x1,5 Ø25.4x1.65	Ø41x1,5 Ø38,1x1,65	Ø53x1,5 Ø50,8x1,65	Ø70x2 Ø63,5x1,65	Ø85x2 Ø76.2x1.65	Ø104x2 Ø101,6x2
D3	-	PA1: Ø 110 PA2: Ø 128	PA1: Ø 110 PA2: Ø 128	PA1: Ø 110 PA2: Ø 128	PA2: Ø 128 PA3: Ø 135	PA3: Ø 135 PA4: Ø 160	PA3: Ø 135 PA4: Ø 160
L1	-	150	170	170	210	230	260
L2	DIN Inch	112 112	132 127.5	155 152	193 189	228 220	269 260
L3	DIN Inch	46 42	59 56	71 69	87 81	106 98	125 122
L4	-	448	447	446	464	531	560
Sp	-	- Rinsing connection with cutting ring union M12x1 / G1/4					
Size when completed							
M (Valve + KI-Top)	-	580	600	625	680	785	850

Table 1 Measurement schedule

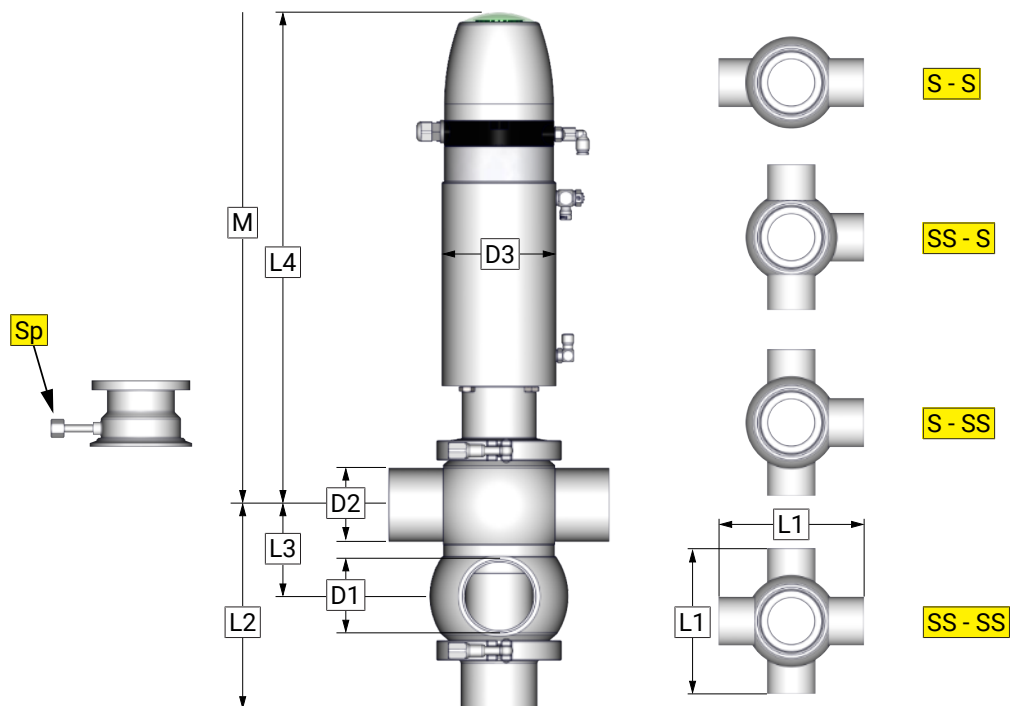

10 Wearing parts

10.1 Double seat valve Type 564x

Seal material: k-flex				
Valve characteristic	Housing VG	Article number	Valve insert VE	Wear parts kit VTS
1. Seal material				
2. Actuator type				
3. Rinsing connection (SP)				
1. k-flex	SS - S	5641 DN 580-xxx		
2. Ø109, Ø135, Ø230	S - S	5642 DN 580-xxx	5640 DN 580-041	5640 DN 509-000
3. -	S - SS	5643 DN 580-xxx		[without support rings for (D4)]
	SS - SS	5644 DN 580-xxx		
1. k-flex	SS - S	5641 DN ???-xxx		
2. Ø109, Ø135, Ø230	S - S	5642 DN ???-xxx	5640 DN ???-041	5640 DN ???-000
3. SP upper	S - SS	5643 DN ???-xxx		[without support rings for (D4)]
	SS - SS	5644 DN ???-xxx		
1. k-flex	SS - S	5641 DN 500-xxx		
2. Ø128, Ø160, Ø230	S - S	5642 DN 500-xxx	5640 DN 500-041	5640 DN 509-000
3. -	S - SS	5643 DN 500-xxx		[without support rings for (D4)]
	SS - SS	5644 DN 500-xxx		
1. k-flex	SS - S	5641 DN ???-xxx		
2. Ø128, Ø160, Ø230	S - S	5642 DN ???-xxx	5640 DN ???-041	5640 DN ???-000
3. SP upper	S - SS	5643 DN ???-xxx		[without support rings for (D4)]
	SS - SS	5644 DN ???-xxx		

Seal material: HNBR / k-flex				
Valve characteristic	Housing VG	Article number	Valve insert VE	Wear parts kit VTS
1. Seal material				
2. Actuator type				
3. Rinsing connection (SP)				
1. HNBR / k-flex	SS - S	5641 DN 582-xxx		
2. Ø109, Ø135, Ø230	S - S	5642 DN 582-xxx	5640 DN 582-041	5640 DN 529-000
3. -	S - SS	5643 DN 582-xxx		[without support rings for (D4)]
	SS - SS	5644 DN 582-xxx		
1. HNBR / k-flex	SS - S	5641 DN ???-xxx		
2. Ø109, Ø135, Ø230	S - S	5642 DN ???-xxx	5640 DN ???-041	5640 DN 579-000
3. SP upper	S - SS	5643 DN ???-xxx		[without support rings for (D4)]
	SS - SS	5644 DN ???-xxx		
1. HNBR / k-flex	SS - S	5641 DN 520-xxx		
2. Ø128, Ø160, Ø230	S - S	5642 DN 520-xxx	5640 DN 520-041	5640 DN 529-000
3. -	S - SS	5643 DN 520-xxx		[without support rings for (D4)]
	SS - SS	5644 DN 520-xxx		
1. HNBR / k-flex	SS - S	5641 DN 570-xxx		
2. Ø128, Ø160, Ø230	S - S	5642 DN 570-xxx	5640 DN 570-041	5640 DN ???-000
3. SP upper	S - SS	5643 DN 570-xxx		[without support rings for (D4)]
	SS - SS	5644 DN 570-xxx		

Seal material: EPDM / k-flex				
Valve characteristic	Housing VG	Article number	Valve insert VE	Wear parts kit VTS
1. Seal material 2. Actuator type 3. Rinsing connection (SP)				
1. EPDM / k-flex 2. Ø109, Ø135, Ø230 3. -	SS - S S - S S - SS SS - SS	5641 DN 583-xxx 5642 DN 583-xxx 5643 DN 583-xxx 5644 DN 583-xxx	5640 DN 583-041	5640 DN 539-000 [without support rings for (D4)]
1. EPDM / k-flex 2. Ø109, Ø135, Ø230 3. SP upper	SS - S S - S S - SS SS - SS	5641 DN ???-xxx 5642 DN ???-xxx 5643 DN ???-xxx 5644 DN ???-xxx	5640 DN ???-041	5640 DN 569-000 [without support rings for (D4)]
1. EPDM / k-flex 2. Ø128, Ø160, Ø230 3. -	SS - S S - S S - SS SS - SS	5641 DN 530-xxx 5642 DN 530-xxx 5643 DN 530-xxx 5644 DN 530-xxx	5640 DN 530-041	5640 DN 539-000 [without support rings for (D4)]
1. EPDM / k-flex 2. Ø128, Ø160, Ø230 3. SP upper	SS - S S - S S - SS SS - SS	5641 DN 560-xxx 5642 DN 560-xxx 5643 DN 560-xxx 5644 DN 560-xxx	5640 DN 560-041	5640 DN ???-000 [without support rings for (D4)]

Seal material: FKM / k-flex				
Valve characteristic	Housing VG	Article number	Valve insert VE	Wear parts kit VTS
1. Seal material 2. Actuator type 3. Rinsing connection (SP)				
1. FKM / k-flex 2. Ø109, Ø135, Ø230 3. -	SS - S S - S S - SS SS - SS	5641 DN 584-xxx 5642 DN 584-xxx 5643 DN 584-xxx 5644 DN 584-xxx	5640 DN 584-041	5640 DN 549-000 [without support rings for (D4)]
1. FKM / k-flex 2. Ø109, Ø135, Ø230 3. SP upper	SS - S S - S S - SS SS - SS	5641 DN ???-xxx 5642 DN ???-xxx 5643 DN ???-xxx 5644 DN ???-xxx	5640 DN ???-041	5640 DN ???-000 [without support rings for (D4)]
1. FKM / k-flex 2. Ø128, Ø160, Ø230 3. -	SS - S S - S S - SS SS - SS	5641 DN 540-xxx 5642 DN 540-xxx 5643 DN 540-xxx 5644 DN 540-xxx	5640 DN 540-041	5640 DN 549-000 [without support rings for (D4)]
1. FKM / k-flex 2. Ø128, Ø160, Ø230 3. 4. 5. SP upper	SS - S S - S S - SS SS - SS	5641 DN ???-xxx 5642 DN ???-xxx 5643 DN ???-xxx 5644 DN ???-xxx	5640 DN ???-041	5640 DN ???-000 [without support rings for (D4)]

DN / OD = Nominal diameter e.g. 5643 050 130-041 = DN50 , 5643 051 130-041 = 2Inch

xxx = Material in product contact / Exterior finish / Control system (Structure of order number)

S = Welded end

Wearing parts kits (VTS) k-flex

Double seat valve Type 564x, DN 40 - 100 / 1½- 4 Inch

Pos	Designation	Material	DN40	DN50	DN65	DN80	DN100	VTS	
			1½Inch	2Inch	2½Inch	3Inch	4Inch		
Wear parts kit (VTS) k-flex - Standard									
	D4 without support ring	k-flex	5640 040 509-000	5640 050 509-000	5640 065 509-000	5640 080 509-000	5640 100 509-000	●	
Wear parts kit (VTS) k-flex - rinsing connection upper									
	D4 without support ring	k-flex	5680 040 ???-000	5680 065 ???-000	5680 050 ???-000	5680 080 ???-000	5680 100 ???-000		●
11	Hexagon nut	AISI304	8113 006 000-020	8113 006 000-020	8113 006 000-020	8113 008 000-020	8113 008 000-020	●	●
18	Headless pin	AISI316L	8112 006 050-040	8112 006 060-040	8112 006 085-040	8112 008 050-040	8112 008 085-040	●	●
D1	Shaft seal (2x) complete	k-flex	5622 050 010-114	5622 050 010-114	5622 065 010-114	5622 080 010-114	5622 100 010-114	●	●
D2	-	-	-	-	-	-	-	-	-
D3	O-ring	EPDM	2304 026 015-170	2304 026 015-170	2304 029 015-170	2304 042 020-170	2304 036 020-170	●	●
D4	Seal (2x) two-parts complete with support ring	k-flex	5621 055 010-114	5621 055 010-114	5621 065 010-114	5621 080 010-114	5621 100 010-114	-	-
	- Support ring	AISI304L	5621 055 011-020	5621 055 011-020	5621 065 011-020	5621 080 011-020	5621 100 011-020	-	-
	- O-ring	EPDM	5621 050 026-159	5621 050 026-159	5621 060 026-159	5621 076 026-159	5621 095 026-159	●	●
	- Form Seal	k-flex	5621 055 012-114	5621 055 012-114	5621 065 012-114	5621 080 012-114	5621 100 100-114	●	●
D5	O-ring	EPDM	2304 041 035-159	2304 041 035-159	2304 050 035-159	2304 066 035-159	2304 085 035-159	●	●
D6	O-ring	EPDM	2304 038 018-170	2304 038 018-170	2304 048 020-170	2304 057 020-170	2304 076 020-170	●	●
D7	O-ring	NBR	2304 042 025-055	2304 042 025-055	2304 042 025-055	2304 046 025-055	2304 046 025-055	●	●
D8	O-ring (2x)	EPDM	2304 036 035-159	2304 036 035-159	2304 036 035-159	2304 041 035-159	2304 041 035-159	●	●
D9	O-ring	EPDM	2304 047 035-159	2304 047 035-159	2304 057 035-159	2304 069 035-159	2304 092 035-159	●	●
D10a	O-ring	EPDM	2304 007 015-159					-	●
D10b	O-ring	NBR	2304 009 020-055					-	●

1) not included in seal kit

Wear parts kits (VTS) HNBR / k-flex

Double seat valve Type 564x, DN 40 - 100 / 1½- 4 Inch

Pos	Designation	Material	DN40 1½Inch	DN50 2Inch	DN65 2½Inch	DN80 3Inch	DN100 4Inch	VTS		
Wear parts kit (VTS) HNBR / k-flex - Standard										
	D4 without support ring	HNBR /k-flex	5640 040 529-000	5640 050 529-000	5640 065 529-000	5640 080 529-000	5640 100 529-000	●		
Wear parts kit (VTS) HNBR / k-flex - rinsing connection upper										
	D4 without support ring	HNBR /k-flex	5640 040 579-000	5640 065 579-000	5640 050 579-000	5640 080 579-000	5640 100 579-000		●	
11	Hexagon nut	AISI304	8113 006 000-020	8113 006 000-020	8113 006 000-020	8113 008 000-020	8113 008 000-020	●	●	
18	Headless pin	AISI316L	8112 006 050-040	8112 006 060-040	8112 006 085-040	8112 008 050-040	8112 008 085-040	●	●	
D1	Shaft seal (2x)	HNBR	5622 050 010-050	5622 050 010-050	5622 065 010-050	5622 080 010-050	5622 100 010-050	●	●	
D2	O-ring (4x)	HNBR	2304 069 026-050	2304 069 026-050	2304 082 026-050	2304 098 035-050	2304 117 035-050	●	●	
D3	O-ring	EPDM	2304 026 015-170	2304 026 015-170	2304 029 015-170	2304 042 020-170	2304 036 020-170	●	●	
D4	Seal (2x) two-parts complete with support ring	k-flex	5621 055 010-114	5621 055 010-114	5621 065 010-114	5621 080 010-114	5621 100 010-114	-	-	
	- Support ring	AISI304L	5621 055 011-020	5621 055 011-020	5621 065 011-020	5621 080 011-020	5621 100 011-020	●	●	
	- O-ring	EPDM	5621 050 026-159	5621 050 026-159	5621 060 026-159	5621 076 026-159	5621 095 026-159	-	-	
	- Form Seal	k-flex	5621 055 012-114	5621 055 012-114	5621 065 012-114	5621 080 012-114	5621 100 100-114	-	-	
D5	O-ring	HNBR	2304 041 035-157	2304 041 035-157	2304 050 035-157	2304 066 035-157	2304 085 035-157	●	●	
D6	O-ring	EPDM	2304 038 018-170	2304 038 018-170	2304 048 020-170	2304 057 020-170	2304 076 020-170	●	●	
D7	O-ring	NBR	2304 042 025-055	2304 042 025-055	2304 042 025-055	2304 046 025-055	2304 046 025-055	●	●	
D8	O-ring (2x)	EPDM	2304 036 035-159	2304 036 035-159	2304 036 035-159	2304 041 035-159	2304 041 035-159	●	●	
D9	O-ring	EPDM	2304 047 035-159	2304 047 035-159	2304 057 035-159	2304 069 035-159	2304 092 035-159	●	●	
D10a	O-ring	EPDM	2304 007 015-159						-	●
D10b	O-ring	NBR	2304 009 020-055						-	●

1) not included in seal kit

Wear part sets (VTS) EPDM / k-flex

Double seat valve Type 564x, DN 40 - 100 / 1½- 4 Inch

Pos	Designation	Material	DN40	DN50	DN65	DN80	DN100	VTS	
			1½Inch	2Inch	2½Inch	3Inch	4Inch		
Wear parts kit (VTS) EPDM / k-flex - Standard									
	D4 without support ring	EPDM /k-flex	5640 040 539-000	5640 050 539-000	5640 065 539-000	5640 080 539-000	5640 100 539-000	●	
Wear parts kit (VTS) EPDM / k-flex - rinsing connection upper									
	D4 without support ring	EPDM /k-flex	5640 040 569-000	5640 050 569-000	5640 065 569-000	5640 080 569-000	5640 100 769-000		●
11	Hexagon nut	AISI304	8113 006 000-020	8113 006 000-020	8113 006 000-020	8113 008 000-020	8113 008 000-020	●	●
18	Headless pin	AISI316L	8112 006 050-040	8112 006 060-040	8112 006 085-040	8112 008 050-040	8112 008 085-040	●	●
D1	Shaft seal (2x)	EPDM	5622 050 010-069	5622 050 010-069	5622 065 010-069	5622 080 010-069	5622 100 010-069	●	●
D2	O-ring (4x)	EPDM	2304 069 026-159	2304 069 026-159	2304 082 026-159	2304 098 035-159	2304 117 035-159	●	●
D3	O-ring	EPDM	2304 026 015-170	2304 026 015-170	2304 029 015-170	2304 042 020-170	2304 036 020-170	●	●
D4	Seal (2x) two-parts complete with support ring	k-flex	5621 055 010-114	5621 055 010-114	5621 065 010-114	5621 080 010-114	5621 100 010-114	-	-
	- Support ring	AISI304L	5621 055 011-020	5621 055 011-020	5621 065 011-020	5621 080 011-020	5621 100 011-020	●	●
	- O-ring	EPDM	5621 050 026-159	5621 050 026-159	5621 060 026-159	5621 076 026-159	5621 095 026-159	-	-
	- Form Seal	k-flex	5621 055 012-114	5621 055 012-114	5621 065 012-114	5621 080 012-114	5621 100 100-114	-	-
D5	O-ring	EPDM	2304 041 035-159	2304 041 035-159	2304 050 035-159	2304 066 035-159	2304 085 035-159	●	●
D6	O-ring	EPDM	2304 038 018-170	2304 038 018-170	2304 048 020-170	2304 057 020-170	2304 076 020-170	●	●
D7	O-ring	NBR	2304 042 025-055	2304 042 025-055	2304 042 025-055	2304 046 025-055	2304 046 025-055	●	●
D8	O-ring (2x)	EPDM	2304 036 035-159	2304 036 035-159	2304 036 035-159	2304 041 035-159	2304 041 035-159	●	●
D9	O-ring	EPDM	2304 047 035-159	2304 047 035-159	2304 057 035-159	2304 069 035-159	2304 092 035-159	●	●
D10a	O-ring	EPDM	2304 007 015-159					-	●
D10b	O-ring	NBR	2304 009 020-055					-	●

1) not included in seal kit

Wear parts kits (VTS) FKM / k-flex

Double seat valve Type 564x, DN 40 - 100 / 1½- 4 Inch

Pos	Designation	Material	DN40 1½Inch	DN50 2Inch	DN65 2½Inch	DN80 3Inch	DN100 4Inch	VTS		
Wear parts kit (VTS) FKM / k-flex - Standard										
	D4 without support ring	FKM /k-flex	5640 040 549-000	5640 050 549-000	5640 065 549-000	5640 080 549-000	5640 100 549-000	●		
Wear parts kit (VTS) FKM / k-flex - rinsing connection upper										
	D4 without support ring	FKM /k-flex	5640 040 ???-00 0	5640 065 ???-00 0	5640 050 ???-00 0	5640 080 ???-00 0	5640 100 ???-00 0	●		
11	Hexagon nut	AISI304	8113 006 000-020	8113 006 000-020	8113 006 000-020	8113 008 000-020	8113 008 000-020	●	●	
18	Headless pin	AISI316L	8112 006 050-040	8112 006 060-040	8112 006 085-040	8112 008 050-040	8112 008 085-040	●	●	
D1	Shaft seal (2x)	FKM	5622 050 010-051	5622 050 010-051	5622 065 010-051	5622 080 010-051	5622 100 010-051	●	●	
D2	O-ring (4x)	FKM	2304 069 026-051	2304 069 026-051	2304 082 026-051	2304 098 035-051	2304 117 035-051	●	●	
D3	O-ring	EPDM	2304 026 015-170	2304 026 015-170	2304 029 015-170	2304 042 020-170	2304 036 020-170	●	●	
D4	Seal (2x) two-parts complete with support ring	k-flex	5621 055 010-114	5621 055 010-114	5621 065 010-114	5621 080 010-114	5621 100 010-114	-	-	
	- Support ring	AISI304L	5621 055 011-020	5621 055 011-020	5621 065 011-020	5621 080 011-020	5621 100 011-020	●	●	
	- O-ring	EPDM	5621 050 026-159	5621 050 026-159	5621 060 026-159	5621 076 026-159	5621 095 026-159	-	-	
	- Form Seal	k-flex	5621 055 012-114	5621 055 012-114	5621 065 012-114	5621 080 012-114	5621 100 100-114	-	-	
D5	O-ring	FKM	2304 041 035-178	2304 041 035-178	2304 050 035-178	2304 066 035-178	2304 085 035-178	●	●	
D6	O-ring	EPDM	2304 038 018-170	2304 038 018-170	2304 048 020-170	2304 057 020-170	2304 076 020-170	●	●	
D7	O-ring	NBR	2304 042 025-055	2304 042 025-055	2304 042 025-055	2304 046 025-055	2304 046 025-055	●	●	
D8	O-ring (2x)	EPDM	2304 036 035-159	2304 036 035-159	2304 036 035-159	2304 041 035-159	2304 041 035-159	●	●	
D9	O-ring	EPDM	2304 047 035-159	2304 047 035-159	2304 057 035-159	2304 069 035-159	2304 092 035-159	●	●	
D10a	O-ring	EPDM	2304 007 015-159						-	●
D10b	O-ring	NBR	2304 009 020-055						-	●

1) not included in seal kit

11 Classification

11.1 Structure of Order Number

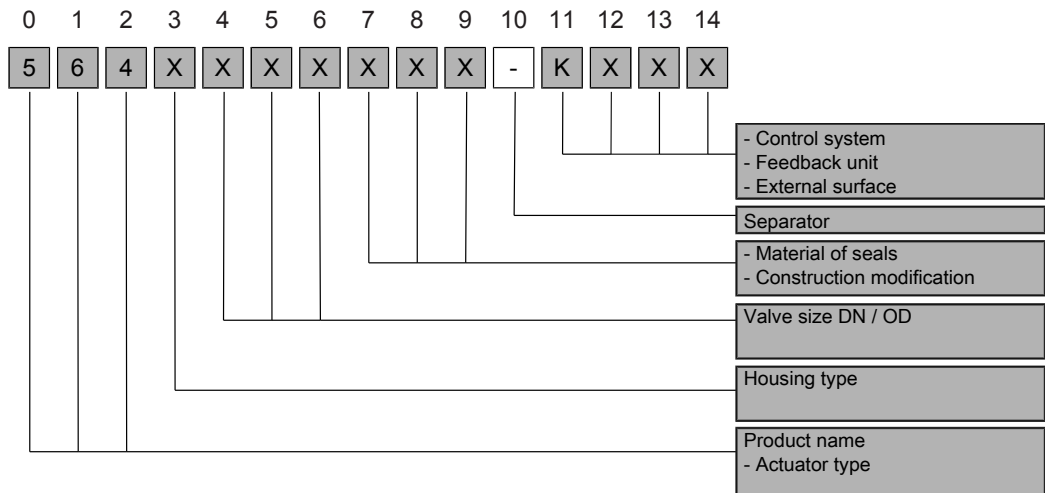

Product name

564x xxx xxx-xxxx	Pos. 0	Pos. 1	Pos. 2
Double seat valve k-flex	5	6	4

Housing type

xxx X xxx xxx-xxxx	Pos. 3
Housing SS - S	1
Housing S - S	2
Housing S - SS	3
Housing SS - SS	4

Valve size

xxxx XXX xxx-xxxx								
Nominal diameter	Pos. 4	Pos. 5	Pos. 6		Nominal diameter	Pos. 4	Pos. 5	Pos. 6
DN 25	0	2	5		DN 80	0	8	0
DN 40	0	4	0		DN 100	1	0	0
DN 50	0	5	0		DN 125	1	2	5
DN 65	0	6	5		DN 150	1	5	0
OD 1"	0	2	6		OD 3"	0	7	6
OD 1 1/2"	0	3	8		OD 4"	1	0	1
OD 2"	0	5	1		OD 5"	1	2	7
OD 2 1/2"	0	6	4		OD 6"	1	5	2

Material of seal / Design modification

xxxx xxx XXX -xxxx				
D4 Seal valve disc	D1 Shaft seal	Pos. 7	Pos. 8	Pos. 9
k-flex	k-flex	5	0	0
k-flex	HNBR	5	2	0
k-flex	EPDM	5	3	0
k-flex	FKM	5	4	0
k-flex	k-flex	8	0	0
k-flex	HNBR	8	2	0
k-flex	EPDM	8	3	0
k-flex	FKM	8	4	0

Separator

xxxx xxx xxx - xxxx	Pos. 10
- Standard	-

Control system, position indicator, surfaces

xxxx xxx xxx- XXXX	Pos. 11	Pos. 12	Pos. 13	Pos. 14
Valve without control system, External surface AISI304 E-polished	0	2	1	
Valve without control system, External surface AISI316L E-polished	0	4	1	
Valve with feedback (5630 005 025-000)	7	5	0	
Valve with control head, KI-Top SPS for double seat valves	K	5	X	X
Valve with control head, KI-Top Asi-Bus for double seat valves	K	6	X	X

12 Appendix

12.1 Declaration of incorporation



Declaration of incorporation

Translation of the original

Manufacturer / authorised representative:

KIESELMANN GmbH
 Paul-Kieselmann-Str. 4-10
 75438 Knittlingen
 Germany

Authorised representative:
 (for compiling technical documents)

Achim Kauselmann
 (Documentation / Development)

 KIESELMANN GmbH
 Paul-Kieselmann-Str. 4-10
 75438 Knittlingen
 Germany

<u>Product name</u>	<u>Function</u>
pneum. Lift actuators	Stroke movement
pneum. Rotary actuators	Rotary movement
Ball valves	Media cutoff
Butterfly valves	Media cutoff
Single seat valves	Media cutoff
Flow control valves	Control of liquefied media
Throttle valve	Control of liquefied media
Overflow valve	Definition of fluid pressure
Double seat valve	Media separation
Bellow valves	Sampling of liquids
Sampling valves	Sampling of liquids
Two way valves	Media cutoff
Tankdome fitting	Prevention of overpressure and vacuum, Tank cleaning
Safety valve	Prevention of overpressure

The manufacturer hereby states that the above product is considered as an incomplete machine in the sense defined in the Directive 2006/42/EC on Machinery. The above product is exclusively intended to be installed into a machine or an incomplete machine. The said product does not yet conform to all the relevant requirements defined in the Directive on Machinery referred to above for this reason.

The specific technical documents listed in Appendix VII, Part B, have been prepared. The Authorized Agent empowered to compile technical documents may submit the relevant documents if such a request has been properly justified.

Commissioning of an incomplete machine must not only be carried out if it has been determined that the respective machine into which the incomplete machine is to be installed conforms to the regulations set out in the Directive on Machinery referred to above.

The above product conforms to the requirements of the directives and harmonized standards specified below:

- Directive 2014/68/EU
- EN ISO 12100 Safety of machinery

Knittlingen, 21.09.2017



 i.V. Uwe Heisswolf
 Head of Development

