



# KIESELMANN

FLUID PROCESS GROUP

Translation of the original

## Operating Instructions

### Double seat tank outlet valve

Type 5629

Seal material: EPDM, HNBR, FKM



**KIESELMANN GmbH**

Paul-Kieselmann-Str. 4-10  
D - 75438 Knittlingen

 +49(0) 7043 371-0 •  +49(0) 7043 371-125  
[www.kieselmann.de](http://www.kieselmann.de) • [info@kieselmann.de](mailto:info@kieselmann.de)

---

Copyright: © KIESELMANN FLUID PROCESS GROUP

## Table of Contents

<b>1</b>	<b>General informations</b>	<b>4</b>
1.1	Informations for your safety	4
1.2	Marking of security instructions	4
1.3	General designated use	4
1.4	Personnel	4
1.5	Modifications, spare parts, accessories	5
1.6	General instructions	5
<b>2</b>	<b>Safety instructions</b>	<b>6</b>
2.1	General notes	6
2.2	General safety instructions	6
<b>3</b>	<b>Delivery, transport and storage</b>	<b>8</b>
3.1	Delivery	8
3.2	Transport	8
3.3	Storage	8
<b>4</b>	<b>Specification</b>	<b>9</b>
4.1	Modular system	9
<b>5</b>	<b>Function and operation</b>	<b>10</b>
5.1	Description of function	10
5.2	Control system and position indicator	10
5.3	Pneumatic valve activation	11
<b>6</b>	<b>Commissioning, service and maintenance</b>	<b>12</b>
6.1	Commissioning	12
6.1.1	Installation instructions	12
6.1.2	General welding guidelines	12
6.1.3	ATEX - Guidelines	12
6.2	Service	13
6.2.1	Maintenance table	13
6.3	Cleaning	13
<b>7</b>	<b>Technical data</b>	<b>14</b>
7.1	Double seat valve Type 5629	14
7.2	Operating pressure	14
7.3	KV - value	15
7.4	Cleaning flow rate	15
7.5	Torques	15
<b>8</b>	<b>Disassembly and assembly</b>	<b>16</b>
8.1	Disassembly	16
8.1.1	Dismount the valve insert (VE)	17
8.1.2	Replacement wear parts	18
8.2	Assembly	20
<b>9</b>	<b>Drawings and dimensions</b>	<b>22</b>
9.1	Drawings	22
9.2	Dimensions	24
9.3	Control units	25
<b>10</b>	<b>Wearing parts</b>	<b>26</b>
10.1	Spare parts list	26
<b>11</b>	<b>Classification</b>	<b>31</b>
11.1	Structure of Order Number	31
<b>12</b>	<b>Appendix</b>	<b>33</b>
12.1	Declaration of incorporation	33

# 1 General informations

## 1.1 Informations for your safety

We are pleased that you have decided for a high-class KIESELMANN product. With correct application and adequate maintenance, our products provide long time and reliable operation.





Before installation and initiation, please carefully read this instruction manual and the security advices contained in it. This guarantees reliable and safe operation of this product and your plant respectively. Please note that an incorrect application of the process components may lead to great material damages and personal injury.

In case of damages caused by non observance of this instruction manual, incorrect initiation, handling or external interference, guarantee and warranty will lapse!

Our products are produced, mounted and tested with high diligence. However, if there is still a reason for complaint, we will naturally try to give you entire satisfaction within the scope of our warranty. We will be at your disposal also after expiration of the warranty. In addition, you will also find all necessary instructions and spare part data for maintenance in this instruction manual. If you don't want to carry out the maintenance by yourself, our KIESELMANN - service team will naturally be at your disposal.

## 1.2 Marking of security instructions

Hints are available in the chapter "safety instructions" or directly before the respective operation instruction. The hints are highlighted with a danger symbol and a signal word. Texts beside these symbols have to be read and adhered to by all means. Please continue with the text and with the handling at the valve only afterwards.

Symbol	Signal word	Meaning
	DANGER	Imminent danger which will result severe personal injury or death.
	WARNING	Imminent danger which may result severe personal injury or death.
	CAUTION	Dangerous situation which may cause slight personal injury or material damages.
	NOTICE	An harmful situation which may result in damages of the product itself or of adjacent vicinity.
	INFORMATION	Marks application hints and other information which is particularly useful.

## 1.3 General designated use

The fitting is designed exclusively for the purposes described below. Using the fitting for purposes other than those mentioned is considered contrary to its designated use. KIESELMANN cannot be held liable for any damage resulting from such use. The risk of such misuse lies entirely with the user. The prerequisite for the reliable and safe operation of the fitting is proper transportation and storage as well as competent installation and assembly. Operating the fitting within the limits of its designated use also involves observing the operating, inspection and maintenance instructions.

## 1.4 Personnel

Personnel entrusted with the operation and maintenance of the tank safety system must have the suitable qualification to carry out their tasks. They must be informed about possible dangers and must understand and observe the safety instructions given in the relevant manual. Only allow qualified personnel to make electrical connections.

## **1.5 Modifications, spare parts, accessories**

Unauthorized modifications, additions or conversions which affect the safety of the fitting are not permitted. Safety devices must not be bypassed, removed or made inactive. Only use original spare parts and accessories recommended by the manufacturer.

## **1.6 General instructions**

The user is obliged to operate the fitting only when it is in good working order. In addition to the instructions given in the operating manual, please observe the relevant accident prevention regulations, generally accepted safety regulations, regulations effective in the country of installation, working and safety instructions effective in the user's plant.

## 2 Safety instructions

### 2.1 General notes



#### NOTICE - observe the operating instructions

To avoid danger and damage, the fitting must be used in accordance with the safety instructions and technical data contained in the operating instructions.



#### NOTICE

All data are in line with the current state of development. Subject to change as a result of technical progress.

### 2.2 General safety instructions



#### ⚠ WARNING

##### Risk of injury by moving parts

Do not grab into the valve when the actuator is pressurized. Limbs can be crushing or amputating.

- Remove the control air line before dismantling.
- Ensure that the actuator is unpressurized.



#### ⚠ WARNING

##### Risk of injury by outflowing medium

Dismantling the valve or valve assemblies from the plant can cause injuries.

- Medias flowing through the leakage drain outlet are to be drained off without splashing into a discharge arrangement.
- Carry the disassembling only if when the plant has been rendered pressure-less and free of liquid and gas.



#### ⚠ WARNING

##### Risk of injury by pre-stressed pressure spring.

The actuator is spring-loaded. When disassembling the actuator, components that jump out may cause injuries.

- For dismantling please observe the separate assembly instructions.
- We recommend having the manufacturer do the maintenance work required for the actuation.



#### ⚠ WARNING

##### ATEX - Guidelines

If the valve or the plant is operated in a potentially explosive atmosphere, the valid ATEX directive of the EC and the installation instructions in this operating manual must be observed.



#### ⚠ CAUTION

When mounting the clamps, the max. torque must not be exceeded.

(see technical data)



#### ⚠ CAUTION

To avoid air leaking, only use pneumatic connection parts that have an O-ring seal facing the even surface.



**⚠ CAUTION**

**Before starting the system, the entire pipeline system must be thoroughly cleaned.**



**⚠ CAUTION**

**Steps should be taken to ensure that no external forces are exerted on the fitting.**

## 3 Delivery, transport and storage

### 3.1 Delivery

- Immediately after receipt check the delivery for completeness and transport damages.
- Remove the packaging from the product.
- Retain packaging material, or expose of according to local regulations.

### 3.2 Transport



#### CAUTION

##### Risk of injury and damage to the product

During the transport the generally acknowledged rules of technology, the national accident prevention regulations and company internal work and safety regulations must be observed.

### 3.3 Storage



#### NOTICE

##### Damage to the product due to improper storage!

Observe storage instructions  
avoid a prolonged storage



#### INFORMATION

##### Recommendation for longer storage







We recommend regularly checking the product and the prevailing storage conditions during long storage times.

- To avoid damage to seals and bearings,
  - products up to DN 125 / OD 5 inch should be stored horizontally for maximum 6 months.
  - products larger than DN 125 / 5 inch, should be stored in the upright position with the actuator on top.
- Don't store any objects on the products.
- Protect the products for wetness, dust and dirt.
- The product should be stored in a dry and well ventilated room at a constant temperature (optimal indoor temperature: 25 C ±5 ; indoor humidity data 70% ±5%).
- Protect seals, bearings and plastic parts for UV light and ozone.



## 4 Specification

### 4.1 Modular system

KI-Top control head		feedback unit
 Stainless steel hood	 Transparent hood	 Feedback unit with finger guard (E)
Valve insert		
		
Sealing material		
		
HNBR	EPDM	FKM
Valve housing		
 Type 5629 (S)	 Type 5629 (SS)	

## 5 Function and operation

### 5.1 Description of function

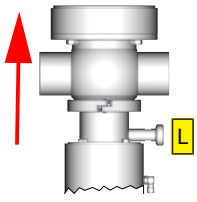

The valve is opened in direction 'X' by means of control air, and is closed from top to bottom by means of spring power without any leakage. Different media fed from the tank or the piping system are separated in a leakage-free fashion by means of two, independently acting valve discs with double seal function. Any leaks occurring due to damaged valve plate seals are drained to the exterior without pressure via the leakage discharge (L).

### 5.2 Control system and position indicator



#### Feedback unit -optional-

Optionally, modular valve control head systems can be installed to the actuator for reading and actuating valve positions. The standard version is a closed system with SPS or ASI-bus switch-on electronics, and integrated 3/2-way solenoid valves. For tough operating conditions we recommend employing a high-grade steel cover.



#### Feedback unit with finger guard -optional-

For the acquisition of the valve positions over inductive initiators (Sensors), a feedback unit is mounted on the actuation. The enquiry takes place over the position of the piston rod.

### 5.3 Pneumatic valve activation

Valve functions	Pneum. activation via control head with solenoid valves (MV)	Pneum. activation via external Solenoid valves (MV external)
main lift valve "OPEN"	Control supply air P - MV1 - P1/LA1	Control supply air ext.MV1 - LA1
main lift valve "CLOSE"	Ventilation P1/LA1 - MV1 - R valve is closing by spring	Ventilation LA1 - ext.MV1 valve is closing by spring
lifting lower seat	OPEN = control air feed P - MV2 - P2/LA2	OPEN = control air feed ext.MV2 - P - LA2
	CLOSE = de-aeration P2/LA2 - MV2 - R valve is closing by spring	CLOSE = de-aeration LA2 - P - ext.MV2 valve is closing by spring
Lifting upper seat	OPEN = control air feed P - MV3 - P3/LA3	OPEN = control air feed ext.MV3 - LA3
	CLOSE = de-aeration P3/LA3 - MV3 - R valve is closing by spring	CLOSE = de-aeration LA3 - ext.MV3 valve is closing by spring

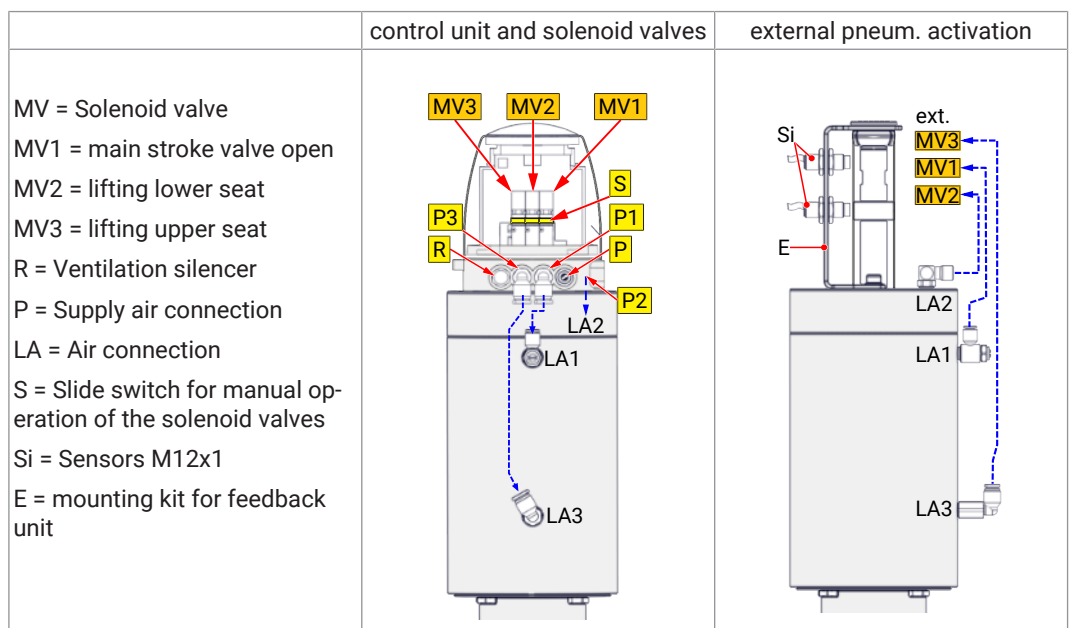

## 6 Commissioning, service and maintenance

### 6.1 Commissioning



#### NOTICE

##### Checking the solenoid valves in the control head

Before using the valve for the first time, the function of the solenoid valves in the control head must be checked.

- Remove the hood on control head.
- Connect the supply air to the control head
- Check the valve functions using the slide switches on the solenoid valve

⇒ Please also read the [documentation for control heads!](#)

#### 6.1.1 Installation instructions

##### Fitting position

The valve must be installed vertically with the actuator at the bottom. Liquid must be able to flow freely from the valve housing and the leakage outlet (L).

#### 6.1.2 General welding guidelines

Sealing elements integrated in weld components must generally be removed prior to welding. To prevent damage, welding should be undertaken by certified personnel (EN ISO 9606-1). Use the TIG (Tungsten Inert Gas) welding process.



#### CAUTION

##### Damage and injuries due to high temperature supply

To avoid a distortion of the components, all welding parts must be welded to stress-relieved. Allow all components to cool before assembling.



#### NOTICE

##### Damage due to impurities

Impurities can cause damage to the seals and seals area.

Clean inside areas prior to assembly.

#### 6.1.3 ATEX - Guidelines

For valves or plants/installations that are operated in the ATEX area, sufficient bonding (grounding) must be ensured (see valid ATEX Guidelines EG).

## 6.2 Service



### RECOMMENDATION

#### Replacement of seals

To achieve optimal maintenance cycles, the following points must be observed!

- When replacement of seals, all product-contacting seals should be replaced.
- Only original spare parts may be installed.

#### Maintenance interval

The maintenance intervals depend on the operating conditions "temperature, temperature-intervals, medium, cleaning medium, pressure and opening frequency". We recommend replacing the seals 1-year cycle. The user, however should establish appropriate maintenance intervals according to the condition of the seals.

#### Lubricant recommendation

	EPDM; HNBR; NBR; FKM; k-flex	- Klüber Paraliq GTE703*
	Silicone	- Klüber Sintheso pro AA2*
	Thread	- Interflon Food*
*) It is only permitted to use approved lubricants, if the respective fitting is used for the production of food or drink. Please observe the relevant safety data sheets of the manufacturers of lubricants.		

#### Maintenance - Lift actuator

The actuator is maintenance-free and non-removable.

### 6.2.1 Maintenance table

		Annually	Additional information
6.2	Service	1	

1 - Maintenance personnel

## 6.3 Cleaning

#### Cleaning

The valve housing is cleaned with the pipe cleaning system when the valve is closed. At the same time, the leakage chamber with the valve shaft is cleaned by cycling the valve disk V2. When cleaning the tank, it is possible to clean the leakage chamber when the valve is closed and the valve disk V1 is cycled. When the valve is open, the valve housing is cleaned via the CIP return line.

## 7 Technical data

### 7.1 Double seat valve Type 5629

Model	Double seat valve			
Size	DIN: DN25 - DN150			
	Inch: OD1 - OD4			
Connection type	Weld-on end DIN EN 10357			
Temperature range	Ambient temperature:	+4°C to +45°C -5°C to +100°C		
	Product temperature: (depends on medium)	-5°C to +100°C		
	Sterilisation temperature: (SIP 30 min)	HNBR	+100°C	
		EPDM	+140°C	
	FKM	+100°C		
Pressure resistance	40 bar			
Leakage rate	A (DIN EN 12266-1)			
Control air	Control air pressure:	5,5 - 8,0 bar		
	Control air quality:	ISO 8573-1 : 2001 quality class 3		
Material (in product contact)	Stainless steel:	1.4404 / AISI 316L		
	Surface:	Ra ≤ 0,8µm e-polished		
	Sealing material:	EPDM (FDA) HNBR (FDA) FKM		

### 7.2 Operating pressure

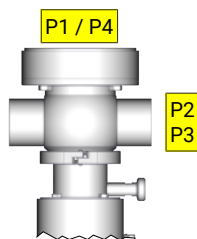

	ND	25	40	50	65	80	100	125	150
	Inch	1	1½	2	2½	3	4	5	6
Tank pressure P1 [bar]:		6	6	6	6	6	6	5	5
Line pressure P2 [bar]:		6	6	6	6	6	6	6	6
Lifting to pipe system P3 [bar]:		4	4	4	4	4	4	4	4
Lifting to tank P4 [bar]:		4	4	4	4	2	2	4	4

### 7.3 KV - value

ND Inch	25 1	40 1½	50 2	65 2½	80 3	100 4	125 5	150 6
flow direction:	[m³/h]							
transition-flow at top ↔	26	50	95	150	240	380	580	940
from tank to pipe system	16	26	45	72	98	155	245	370

### 7.4 Cleaning flow rate

#### Cleaning parameters for the leakage chamber

Cleaning step	valve disc lifting	DIN Inch	25 1	40 1½	50 2	65 2½	80 3	100 4	125 5	150 6
Pre-Rinse	-	lifting upper seat	0,97	1,10	1,1	1,38	1,66	2,08	2,50	4,02
Lye 80°C	3 x 5 sec.									
Intermediate rinse	2 x 5 sec.		(l/s bei 3bar)							
Acid	3 x 5 sec.	lifting lower seat	0,54	0,69	0,69	0,83	0,83	1,25	1,66	2,50
Final rinse	2 x 5 sec.									

### 7.5 Torques

#### Torque: clamp coupling

ND Inch	25 1	40 1½	50 2	65 2½	80 3	100 4	125 5	150 6
Torque [Nm]	15	15	15	25	25	55	65	65

#### Torque: clamp coupling

ND Inch	40 1½	50 2	65 2½	80 3
Torque [Nm]	15	15	25	25

#### Torque: clamp coupling

DN Inch	25 1	40 1½	50 2	65 2½	80 3	100 4
Torque [Nm]	15	15	15	25	25	55

## 8 Disassembly and assembly

### 8.1 Disassembly









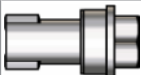
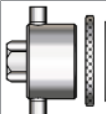

#### NOTICE

All threaded joint have right-hand thread.

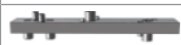
Unscrew and remove control air, steam resp. cleaning lines and electrical lines, complete feedback unit or control head.

#### Assembly Tools

Mounting tools sets:		DN40 - DN65	5670 065 100-000	●		
		DN80 - DN100	5670 100 100-000		●	
		DN125 - DN150	5670 150 100-000			●
ST1		Socket	DN40 - DN65	5620 065 131-130	●	
			DN80 - DN150	5620 100 131-130		● ●
ST2		Socket + guide bush (POM) + O-rings	DN40 - DN65	5670 080 105-000	● ●	
			DN80 - DN100	5670 100 105-000		●
			DN125 - DN150	5670 150 105-000		●
ST3		Eccentric socket	DN40 - DN65	5620 065 134-130	●	
			DN80 - DN150	5620 100 134-130		● ●
ST4		Centring ring	DN40/50	5620 050 025-020	●	
			DN65	5620 065 025-020		●
			DN80	5620 080 025-020		●
			DN100	5620 100 025-020		●
			DN125	5620 125 025-020		●
			DN150	5620 150 025-020		●
T10		Joint -pin wrench	DN40 - DN65	5620 065 015-000	●	
			DN80 - DN150	5620 150 015-000		● ●
ST1 5		Mounting plate	DN40 - DN65	5620 065 121-020	●	
			DN80 - DN100	5620 100 121-020		●
			DN125 - DN150	5620 150 121-020		●

Pos.	Figure	Designation		Article number
T1		Combination wrench-Set	SW 8 - SW 24	-
T4		Soft-head hammer	-	-
T40		Socket box	SW8 - SW36	-
ST16		Mounting wrench	DN 40 - 150	5670150126-020



### 8.1.1 Dismount the valve insert (VE).



#### ⚠ CAUTION

##### Risk of injury by falling parts

First secure the valve insert (VE) against falling down. For example, with lugs (L) and a safety chain.

- Then open the clamp coupling (VK).

- Unscrew the clamp coupling (VK).
- Remove the complete valve insert with the shaft seal (D1) from the housing (VG).

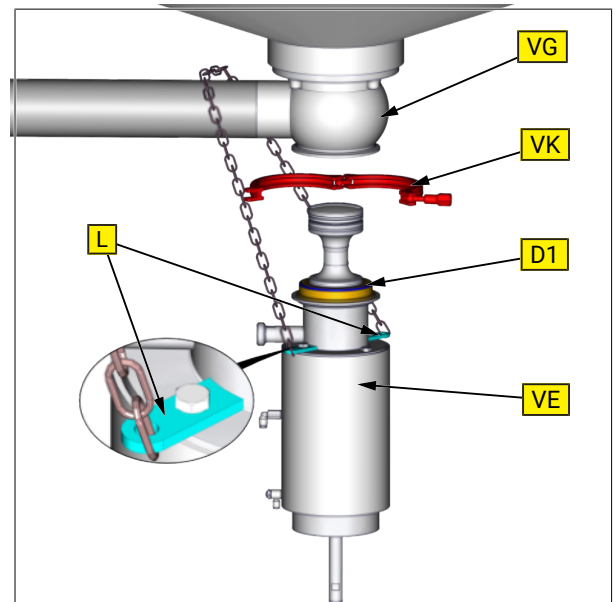

- Unscrew the screws (1).
- Remove the housing (VG) and remove the sealing ring (D7).

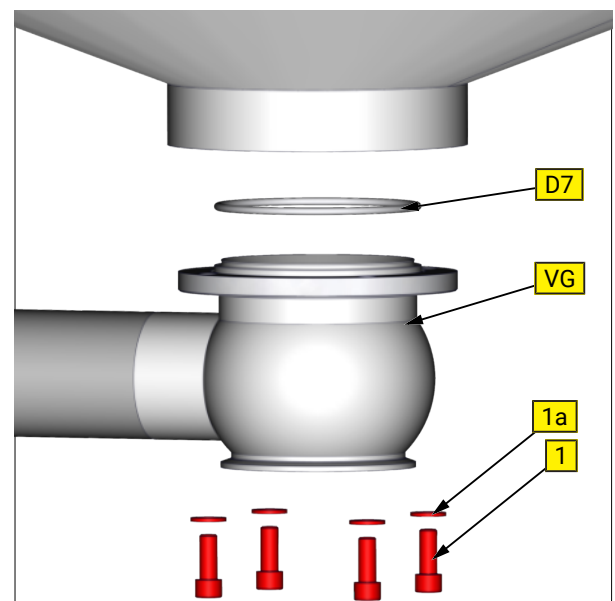

### 8.1.2 Replacement wear parts

- Unscrew the lower piston (6) from the upper piston (7) with the assembly tool ST16. Hold against the spanner flat SW17.
- Remove piston plate (9), O-ring (D3), (D5) and seal (D4).

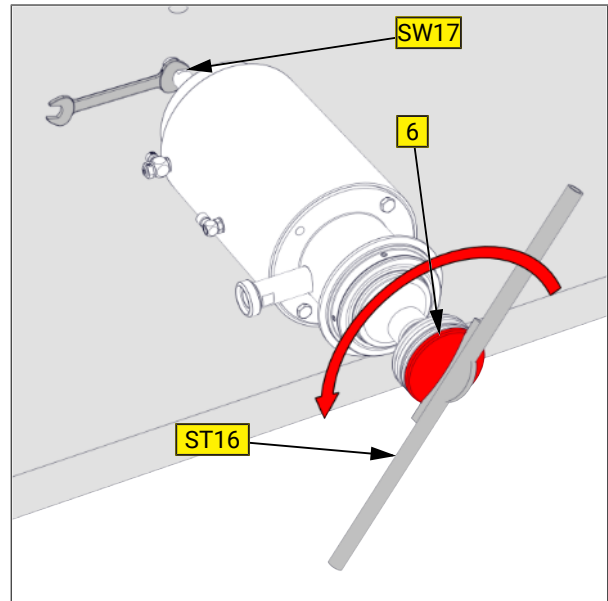

- Unscrew the hexagon screws (14).
- Push the lantern (13) with shaft seal (D1) in direction 'X', until the hole (B) is freely visible.

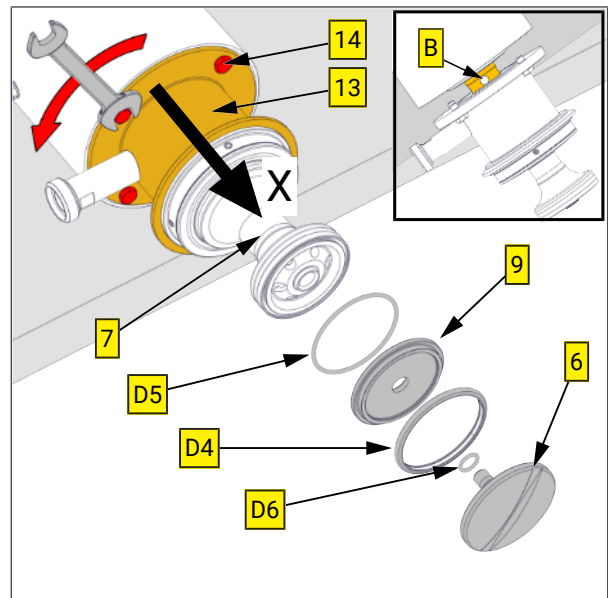

- Unscrew the upper piston (7) with the mounting plate ST15 from piston rod (3).  
Hold against the hole (B) with a pin spanner T10.

**NOTICE!**

Valve  $\geq$  DN 40 / 1½"

(Valves with divided pistons):

- If the piston plate (8) loosens before the piston (7), then unscrew the piston (7) with the eccentric ST3 and a ratchet.

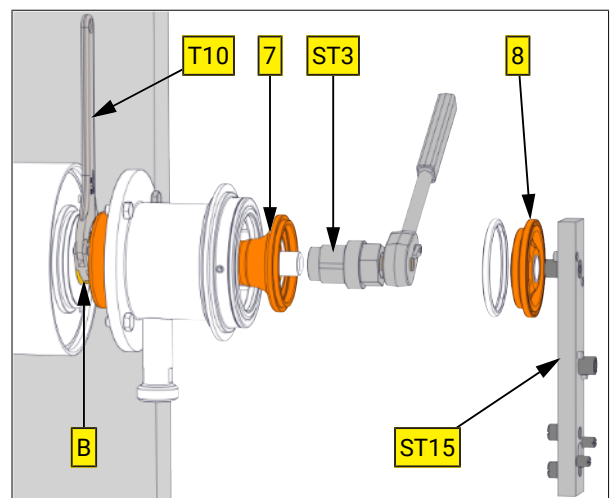
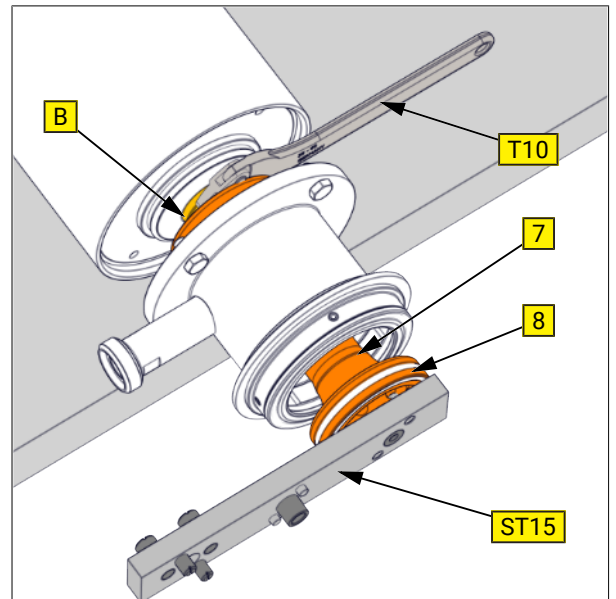

Remove the rinsing connection (Sp) from lantern (13) and dismount the O-ring (D11).

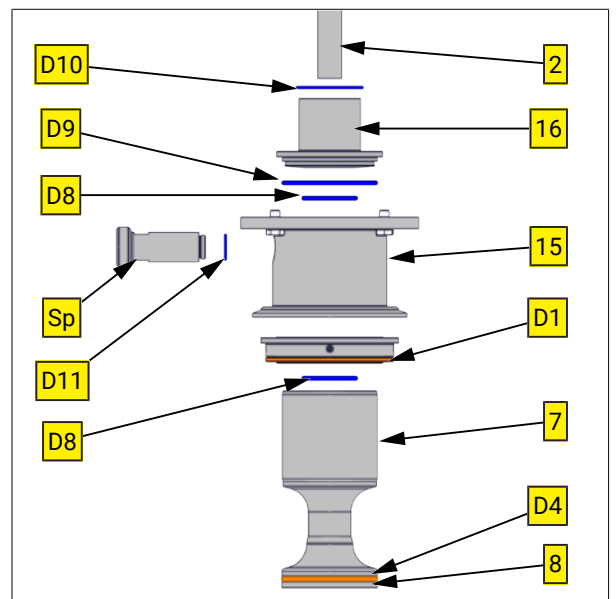

## 8.2 Assembly

### Mounting seal (D4), pair of piston (7)/(8)

Pair of piston upper = Piston (7) and piston plate (8)

- Screw together the piston plate (7) / (8) without the seal (D4) to the metal limit stop by hand.
- Make a colored mark at the piston surfaces.
- After then, unscrew the pairs of piston again.

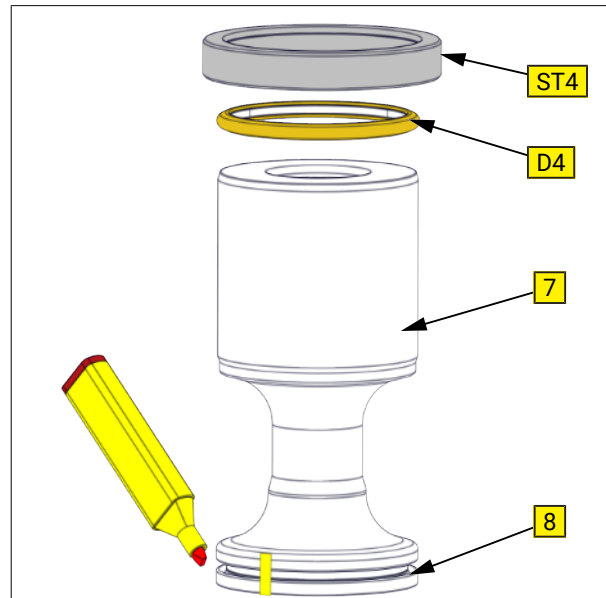

- Slide the seal (D4) onto the piston (7).
- Screw together the pair of piston by hand again.
- Clamp the mounting plate M6 into the vice.
- Position the eccentric ring (ST4) on seal (D4).
- Screw up the piston (7) with the socket ST1 and a ratchet to the final limit mark.

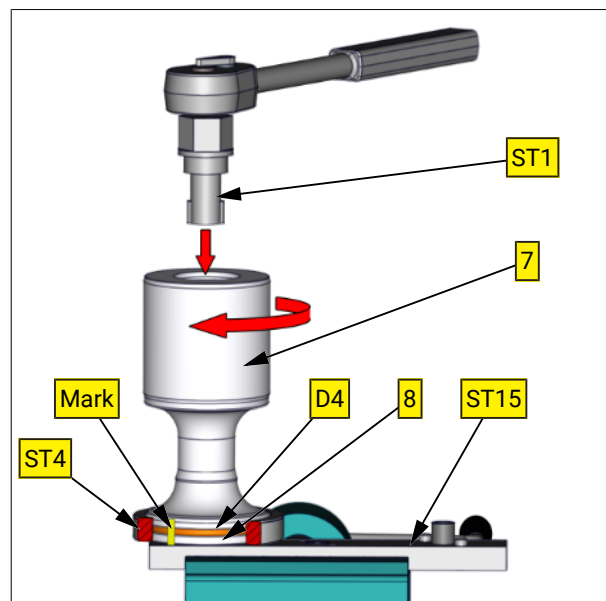

### Mounting seal (D4), pair of piston (6)/(9)

Pair of piston upper = Piston (6) and piston plate (9)

- Screw together the piston plate (6) / (9) without the seal (D4) and O-ring (D5) to the metal limit stop by hand.
- Make a colored mark at the piston surfaces.
- After then, unscrew the pairs of piston again.

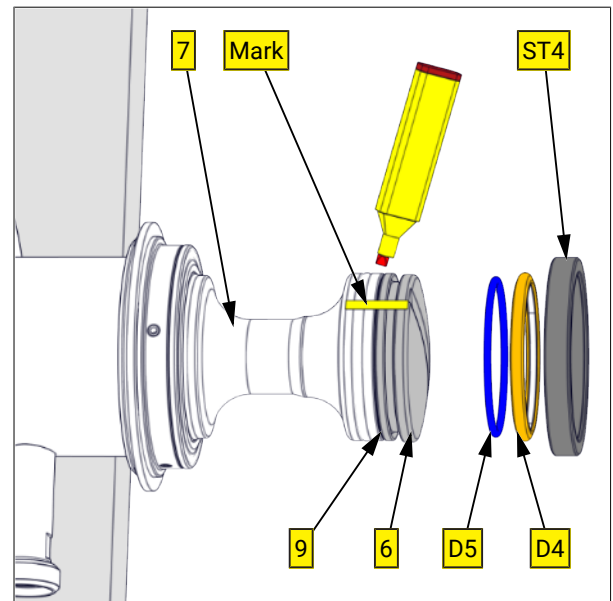

- Slide the seal (D4) onto the piston plate (9).
- Mounting O-ring (D5 and D6).
- Screw together the pair of piston by hand again.

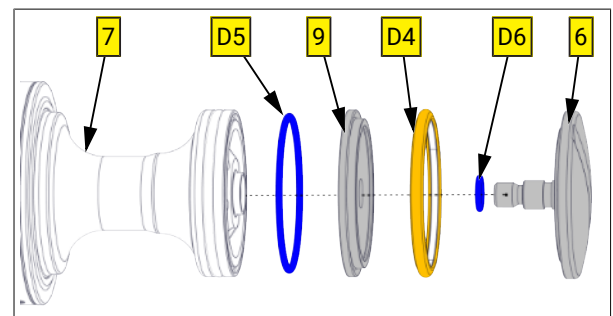

- Position the eccentric ring (ST4) on seal (D4).
  - With a mounting wrench ST16 screw up the piston (6) to the final limit mark.
- Hold on at the spanner flat (SW17)

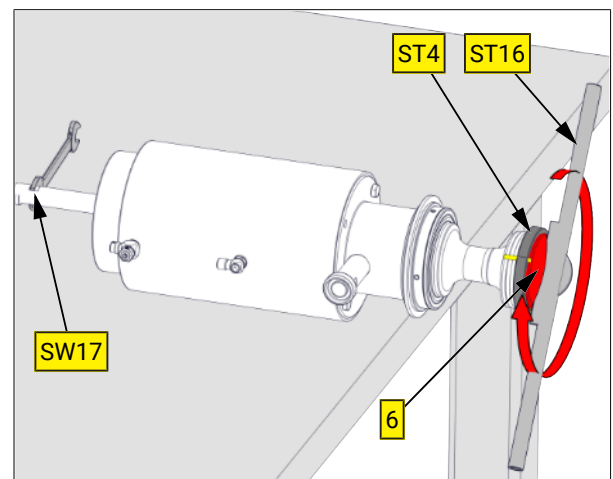

## 9 Drawings and dimensions

### 9.1 Drawings

#### Double seat tank outlet valve Type 5629

1 = Screws

1a = Washer

13 = Lantern with rinsing connection

14 = Screws

F1 = Flange

F2 = Flange

S = Circlip

K = Cap

VE = Valve insert

VG = Valve housing

VK = Clamp coupling

Sp = Screwed socket

D1 = Shaft seal

D7 = O-ring

D11 = O-ring

D12 = O-ring

LA1 = air supply valve stroke

LA2 = air supply lifting lower seat

LA3 = air supply lifting upper seat

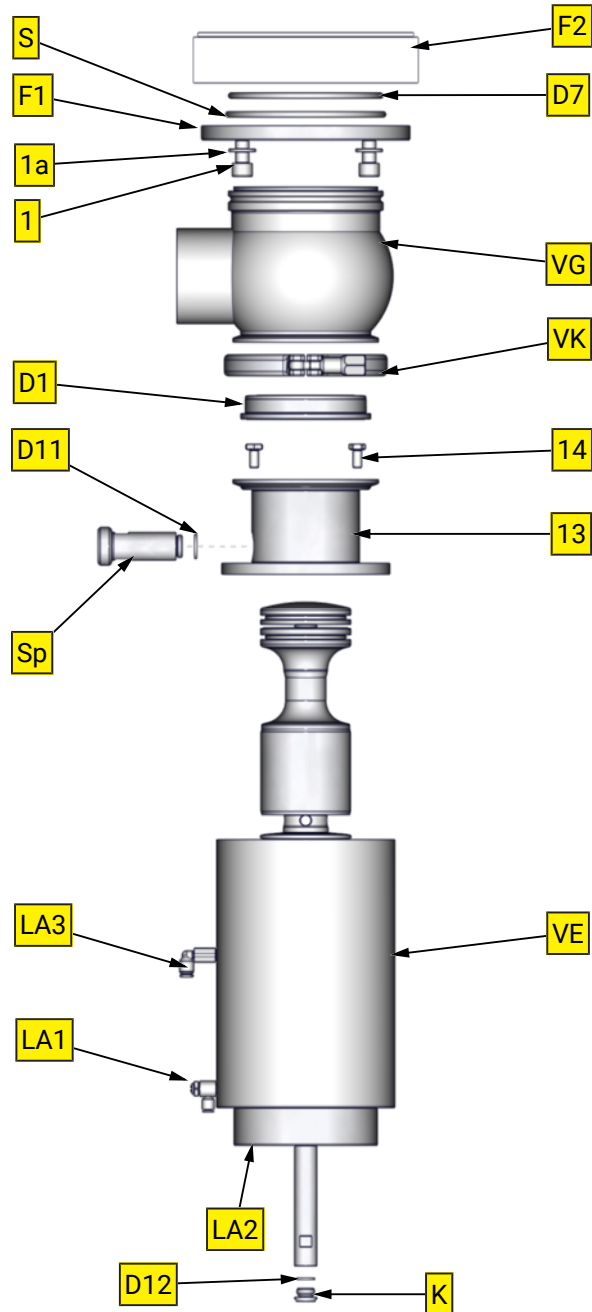

**Valve insert VE**

- 1 = -
- 2 = Spindle
- 3 = Piston rod
- 4 = Bearing bush
- 5 = Insert
- 6 = Piston
- 7 = Piston
- 8 = Piston plate
- 9 = Piston plate
- 10 = Plain bearing
- 11 = Valve lift stop
- 12 = pneum. Drive
- 13 = Lantern
- 14 = Screws
- 15= Plain bearing

- D1 = Shaft seal
- D2 = O-rings
- D3 = O-ring
- D4 = Seal ring with with support ring
- D5 = O-ring
- D6 = O-ring
- D7 = -
- D8 = O-rings
- D9 = O-ring
- D10 = O-ring
- D11 = O-ring

- VE = Valve insert
- Sp = Screwed socket
- G1 = Screw retention detachable  
(e.g. Loctite 243)
- Y = Detail

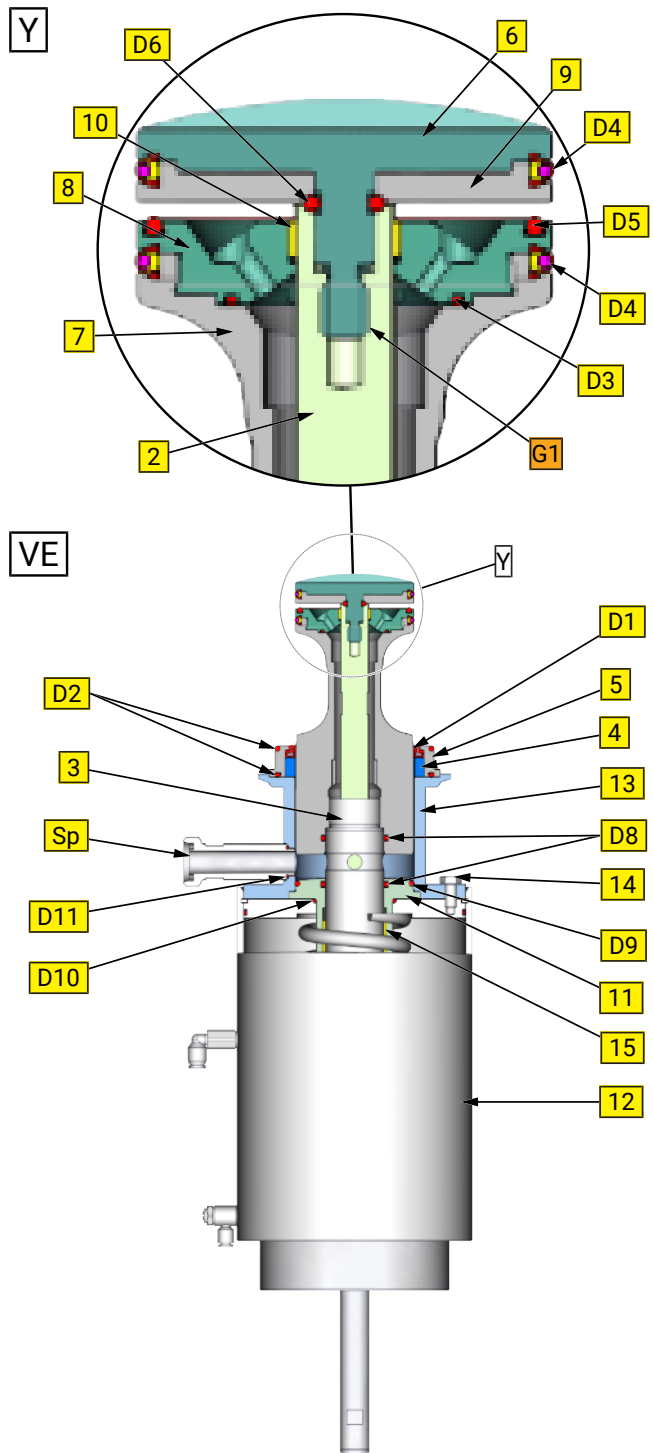

### 9.2 Dimensions

	DIN	25	40	50	65	80	100	125	150
	Inch	1	1½	2	2½	3	4	5	6
D1	DIN	Ø29x1,5	Ø41x1,5	Ø53x1,5	Ø70x2	Ø85x2	Ø104x2	Ø129x2	Ø 154x2
	Inch	Ø25.4x1.65 (DN50 red.)	Ø38,1x1,65 (DN50 red.)	Ø50,8x1,65	Ø63,5x1,65	Ø76.2x1.65	Ø101,6x2	-	-
D2		Ø 128	Ø 128	Ø 128	Ø 128	Ø 160	Ø 160	Ø 230	Ø 230
G		- Standard rinsing connection screwed socket DN15DIN 11851							
L1		151	118	85	105	115	130	160	172.5
L2	DIN	57.7	61.35	46	66	71	92	104	109.5
	Inch	-	-	44.9	62.75	66.55	90.8	-	-
L3	DIN	434	443	497	535	609	660	725	617
<b>Assembly dimension M</b>									
M (incl. control head)		540	550	560	580	720	730	815	855

Table 1 Measurement schedule [mm]

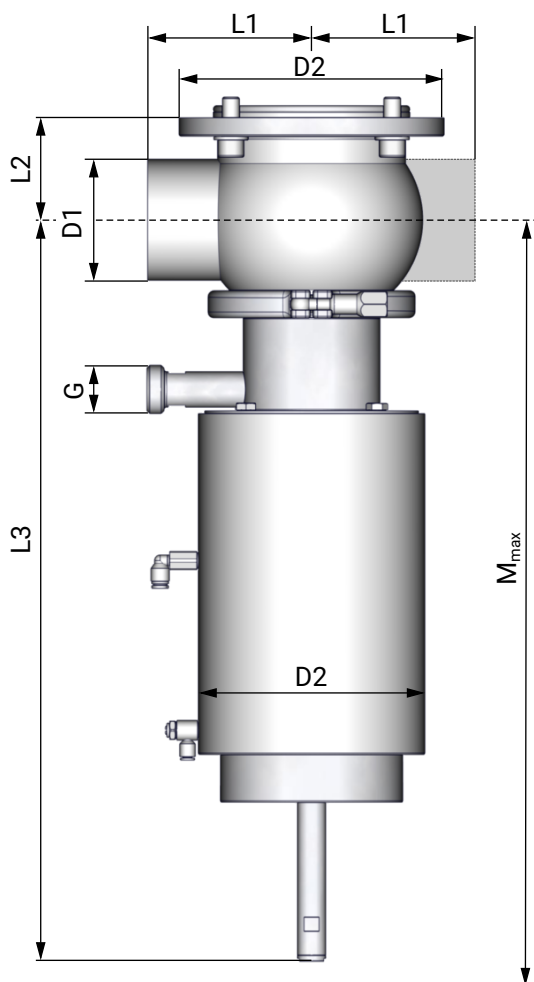

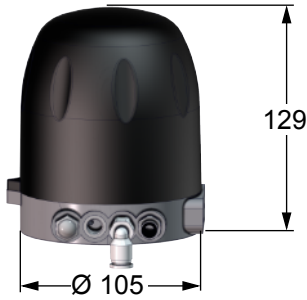
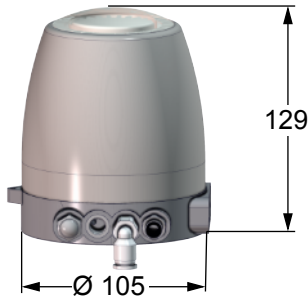
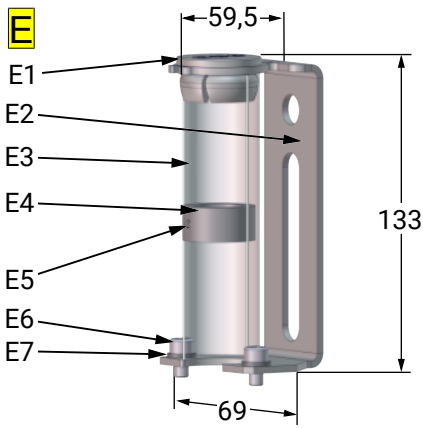
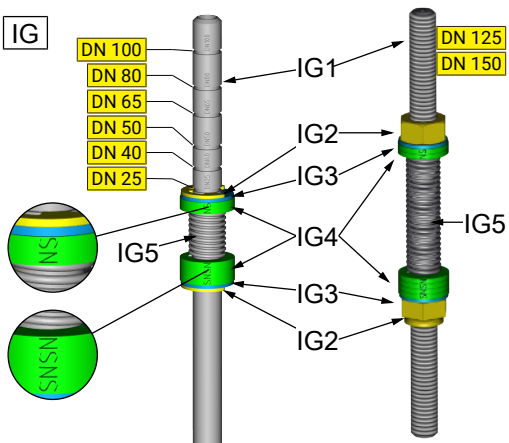

### 9.3 Control units

Control head KI-TOP	
with plastic hood - transparent	with stainless steel hood
	
Feedback unit with finger guard (E)	
<ul style="list-style-type: none"> <li>• E1 = Cap</li> <li>• E2 = Angle bracket</li> <li>• E3 = Shell transparent</li> <li>• E4 = Set collar</li> <li>• E5 = Headless pin</li> <li>• E6 = Allen screw</li> <li>• E7 = Flat washer</li> </ul>	
Pulse generator (IG) - Double seat valve	
<ul style="list-style-type: none"> <li>• IG1 = Rod</li> <li>• IG2 = Circlip ring / nut</li> <li>• IG3 = Disc</li> <li>• IG4 = Magnet</li> <li>• IG5 = Spring</li> </ul>	

## 10 Wearing parts

### 10.1 Spare parts list

Housing	Seal	Item number	Valve insert VE	Wear parts kit		
S	EPDM	5629 DN 730-xxx	5629 DN 735-041	a)	5629 DN 739-020	with support ring (D4)
S - S		5629 DN 732-xxx		b)	5629 DN 739-000	without support ring (D4)
S	HNBR	5629 DN 720-xxx	5629 DN 725-041	a)	5629 DN 729-020	with support ring (D4)
S - S		5629 DN 722-xxx		b)	5629 DN 729-000	without support ring (D4)
S	FKM	5629 DN 740-xxx	5629 DN 745-041	a)	5629 DN 749-020	with support ring (D4)
S - S		5629 DN 742-xxx		b)	5629 DN 749-000	without support ring (D4)

DN = Nominal diameter e.g. 5629 050 730-041 = DN50; 5629 051 730-041 = 2Inch

xxx = Materials in product contact / Exterior finish / Control systems (Structure of order number)

S = Welded end

No.	Designation	Material	DN25	DN40	DN50	DN65
F2	Flange optional Welding flange	AISI316L	5629 050 002-040	5629 050 002-040	5629 050 002-040	5629 065 002-040
VG	Housing S	AISI316L	5629 025 221-041	-	5629 050 001-041	5629 065 001-041
	Housing S - S	AISI316L	5629 025 011-041	5629 040 731-041	5629 050 011-041	5629 065 005-041
1	Hexagon screw	AISI304	8106 010 025-020 DIN933 M10x25 (4x)	8106 010 025-020 DIN933 M10x25 (4x)	8106 010 025-020 DIN933 M10x25 (4x)	8095 012 025-020 DIN912 M12x25 (4x)
1a	Washer	AISI304	8071 105 001-020 DIN125 A10.5 (4x)	8071 105 001-020 DIN125 A10.5 (4x)	8071 105 001-020 DIN125 A10.5 (4x)	8071 130 001-020 DIN125 A13 (4x)
F1	Flange	AISI316L	5727 050 004-041	5727 050 004-041	5727 050 004-041	5727 065 004-041
SR	Retaining ring	AISI301	5757 050 003-031	5757 050 003-031	5757 050 003-031	5757 065 003-031
VK	Locking clip	AISI304	2122 065 100-020	2122 065 100-020	2122 065 100-020	2122 080 100-020

No.	Designation	Material	DN80	DN100	DN125	DN150
F2	Flange optional	AISI316L	5629 080 002-040	5629 100 010-040	5629 125 002-040	-
VG	Housing S	AISI316L	5629 080 711-041	5629 100 001-041	5629 125 001-041	-
	Housing S - S	AISI316L	5629 080 714-041	5629 100 011-041	5629 125 011-041	-
1	Hexagon screw	AISI304	8106 012 030-020 DIN933 M12x30 (4x)	8106 012 030-020 DIN933 M12x30 (6x)	8106 010 030-020 DIN933 M10x30 (8x)	-
1a	Washer	AISI304	8071 130 001-020 DIN125 A13 (6x)	8071 130 001-020 DIN125 A13 (6x)	8071 105 001-020 DIN125 A10.5 (8x)	-
F1	Flange	AISI316L	5727 080 004-041	5727 100 004-041	5727 125 004-041	-
SR	Retaining ring	AISI301	5757 080 003-031	5757 100 003-031	5757 125 003-031	-
VK	Locking clip	AISI304	2122 115 100-020	2122 125 100-020	2122 150 100-020	-

## Spare-parts list - Valve insert

No.	Designation	Material	DN50 red DN25	DN50 red DN40	DN50	DN65
VE	Valve insert EPDM	EPDM	5629 050 735-041	5629 050 735-041	5629 050 735-041	5629 065 735-041
VE	Valve insert HNBR	HNBR	5629 050 725-041	5629 050 725-041	5629 050 725-041	5629 065 725-041
VE	Valve insert FKM	FKM	5629 050 745-041	5629 050 745-041	5629 050 745-041	5629 065 745-041
4	Bearing bush	PTFE	5622 050 006-053	5622 050 006-053	5622 050 006-053	5622 065 006-053
5	Housing-insert	AISI316L	5622 050 005-040	5622 050 005-040	5622 050 005-040	5622 065 005-040
6	Piston lower	AISI316L	5628 050 006-040	5628 050 006-040	5628 050 006-040	5628 065 006-040
7	Piston upper	AISI316L	5621 050 007-040	5621 050 007-040	5621 050 007-040	5621 065 007-040
8	Piston plate upper	AISI316L	5621 050 006-040	5621 050 006-040	5621 050 006-040	5621 065 006-040
9	Piston plate lower	AISI316L	5628 050 007-040	5628 050 007-040	5628 050 007-040	5628 065 007-040
10	Slide bearing	XMS	8050 015 007-156	8050 015 007-156	8050 015 007-156	8050 015 007-156
11	Valve lift stop	AISI303	5622 050 009-220	5622 050 009-220	5622 050 009-220	5622 065 009-220
12	pneumatic actuator	AISI304	5628 050 000-021	5628 050 000-021	5628 050 000-021	5628 065 000-021
13	Lantern complete	AISI304	5628 050 010-021	5628 050 010-021	5628 050 010-021	5628 065 010-021
	- Lantern	AISI304	5628 050 009-021	5628 050 009-021	5628 050 009-021	5628 065 009-021
SP	- Screw-in socket	AISI304	5624 065 514-020	5624 065 514-020	5624 065 514-020	5624 065 514-020
D11	- O-ring	EPDM	2304 014 020-170	2304 014 020-170	2304 014 020-170	2304 014 020-170
14	Hexagon screws	AISI304	8106 008 016-020	8106 008 016-020	8106 008 016-020	8106 008 016-020
15	Slide bearing	XMS	8050 035 030-156	8050 035 030-156	8050 035 030-156	8050 035 030-156
D12	O-ring	NBR	2304 012 020-055	2304 012 020-055	2304 012 020-055	2304 012 020-055
K	Cap	AISI303	5622 100 071-220	5622 100 071-220	5622 100 071-220	5622 100 071-220
SP	Screw-in socket	AISI304	5624 065 514-020	5624 065 514-020	5624 065 514-020	5624 065 514-020

No.	Designation	Material	DN80	DN100	DN125	DN150
VE	Valve insert EPDM	EPDM	5629 080 735-041	5629 100 735-041	5629 125 735-041	-
VE	Valve insert HNBR	HNBR	5629 080 725-041	5629 100 725-041	5629 125 725-041	-
VE	Valve insert FKM	FKM	5629 080 745-041	5629 100 745-041	5629 125 745-041	-
4	Bearing bush	PTFE	5622 080 006-053	5622 100 006-053	5622 125 006-053	-
5	Housing-insert	AISI316L	5622 080 005-040	5622 100 005-040	5622 125 005-040	-
6	Piston lower	AISI316L	5628 080 006-040	5628 100 006-040	5628 125 006-040	-
7	Piston upper	AISI316L	5621 080 007-040	5621 100 007-040	5621 125 007-040	-
8	Piston plate upper	AISI316L	5621 080 006-040	5621 100 006-040	5621 125 006-040	-
9	Piston plate lower	AISI316L	5628 080 007-040	5628 100 007-040	5628 125 007-040	-
10	Slide bearing	XMS	8050 020 007-156	8050 020 007-156	8050 020 007-156	-
11	Valve lift stop	AISI303	5622 080 009-220	5622 100 009-220	5622 125 009-220	-
12	pneumatic actuator	AISI304	5628 080 000-021	5628 100 000-021	5620 150 000-021	-
13	Lantern complete	AISI304	5628 080 010-021	5628 100 010-021	5628 125 010-021	-
	- Lantern	AISI304	5628 080 009-021	5628 100 009-021	5628 150 011-021	-
SP	- Screw-in socket	AISI304	5624 100 514-020	5624 100 514-020	5624 150 514-020	-
D11	- O-ring	EPDM	2304 016 020-170	2304 016 020-170	2304 016 020-170	-
14	Hexagon screws	AISI304	8106 008 016-020	8106 008 016-020	8106 008 025-020	-
15	Slide bearing	XMS	8050 040 030-156	8050 040 030-156	8050 040 030-156	-
D12	O-ring	NBR	2304 012 020-055	2304 012 020-055	2304 012 020-055	-
K	Cap	AISI303	5622 100 071-220	5622 100 071-220	5622 100 071-220	-

**Seal kit EPDM**

No.	Designation	Material	DN50 red DN25	DN50 red DN40	DN50	DN65
	Seal kit a)	EPDM	5629 050 739-020	5629 050 739-020	5629 050 739-020	5629 065 739-020
	Seal kit b)	EPDM a)	5629 050 739-000	5629 050 739-000	5629 050 739-000	5629 065 739-000
D1	Shaft seal	EPDM	5622 050 010-069	5622 050 010-069	5622 050 010-069	5622 065 010-069
D2	O-ring (2x)	EPDM	2304 069 026-159	2304 069 026-159	2304 069 026-159	2304 082 026-159
D3	O-ring	EPDM	2304 026 015-170	2304 026 015-170	2304 026 015-170	2304 029 015-170
D4	a) Seal (2x)	EPDM	5621 055 025-084	5621 055 025-084	5621 055 025-084	5621 065 025-084
	- Jacket	EPDM	5621 055 026-084	5621 055 026-084	5621 055 026-084	5621 065 026-084
	- Support ring	AISI303	5621 055 027-020	5621 055 027-020	5621 055 027-020	5621 065 027-020
	b) Seal (2x)		5621 050 010-084	5621 050 010-084	5621 050 010-084	5621 065 010-084
D5	O-ring	EPDM	2304 041 035-159	2304 041 035-159	2304 041 035-159	2304 050 035-159
D6	O-ring	EPDM	2304 008 020-069	2304 008 020-069	2304 008 020-069	2304 008 020-069
D7	O-ring	EPDM	2304 088 035-159	2304 088 035-159	2304 088 035-159	2304 110 035-159
D8	O-ring	EPDM	2304 036 035-159	2304 036 035-159	2304 036 035-159	2304 036 035-159
D9	O-ring	EPDM	2304 047 035-159	2304 047 035-159	2304 047 035-159	2304 057 035-159
D10	O-ring	NBR	2304 042 025-055	2304 042 025-055	2304 042 025-055	2304 042 025-055

No.	Designation	Material	DN80	DN100	DN125	DN150
	Seal kit a)	EPDM	5629 080 739-020	5629 100 739-020	5629 125 739-020	5629 150 739-020
	Seal kit b)	EPDM	5629 080 739-000	5629 100 739-000	5629 125 739-000	5629 150 739-000
D1	Shaft seal	EPDM	5622 080 010-069	5622 100 010-069	5622 125 010-069	-
D2	O-ring (2x)	EPDM	2304 098 035-159	2304 117 035-159	2304 142 035-159	-
D3	O-ring	EPDM	2304 042 020-170	2304 036 020-170	2304 036 020-170	-
D4	a) Seal (2x)	EPDM	5621 080 025-084	5621 100 025-084	5621 125 025-084	-
	- Jacket	EPDM	5621 080 026-084	5621 100 026-084	5621 125 026-084	-
	- Support ring	AISI303	5621 080 027-020	5621 100 027-020	5621 125 027-020	-
	b) Seal (2x)	EPDM	5621 080 010-084	5621 100 010-084	2304 113 053-084	-
D5	O-ring	EPDM	2304 066 035-159	2304 085 035-159	2304 111 035-084	-
D6	O-ring	EPDM	2304 012 030-170	2304 012 030-170	2304 012 030-170	-
D7	O-ring	EPDM	2304 127 050-159	2304 158 035-159	2304 164 053-054	-
D8	O-ring	EPDM	2304 041 035-159	2304 041 035-159	2304 041 035-159	-
D9	O-ring	EPDM	2304 069 035-159	2304 092 035-159	2304 117 035-159	-
D10	O-ring	NBR	2304 046 025-055	2304 046 025-055	2304 046 025-055	-

**Seal kit HNBR**

No.	Designation	Material	DN25	DN40	DN50	DN65
	Seal kit a)	HNBR	5629 025 729-020	5629 040 729-020	5629 050 729-020	5629 065 729-020
	Seal kit b)	HNBR	5629 025 729-000	5629 040 729-000	5629 050 729-000	5629 065 729-000
D1	Shaft seal	HNBR	5622 050 010-050	5622 050 010-050	5622 050 010-050	5622 065 010-050
D2	O-ring (2x)	HNBR	2304 069 026-050	2304 069 026-050	2304 069 026-050	2304 082 026-050
D3	O-ring	EPDM	2304 026 015-170	2304 026 015-170	2304 026 015-170	2304 029 015-170
D4	a) Seal (2x)	HNBR	5621 055 025-171	5621 055 025-171	5621 055 025-171	5621 065 025-171
	- Jacket	HNBR	5621 055 026-171	5621 055 026-171	5621 055 026-171	5621 065 026-171
	- Support ring	AISI303	5621 055 027-020	5621 055 027-020	5621 055 027-020	5621 065 027-020
	b) Seal (2x)	HNBR	5621 050 010-157	5621 050 010-157	5621 050 010-157	5621 065 010-157
D5	O-ring	HNBR	2304 041 035-157	2304 041 035-157	2304 041 035-157	2304 050 035-157
D6	O-ring	EPDM	2304 008 020-069	2304 008 020-069	2304 008 020-069	2304 008 020-069
D7	O-ring	HNBR	2304 085 035-157	2304 085 035-157	2304 085 035-157	2304 111 035-050
D8	O-ring	EPDM	2304 036 035-159	2304 036 035-159	2304 036 035-159	2304 036 035-159
D9	O-ring	EPDM	2304 047 035-159	2304 047 035-159	2304 047 035-159	2304 057 035-159
D10	O-ring	NBR	2304 042 025-055	2304 042 025-055	2304 042 025-055	2304 042 025-055

No.	Designation	Material	DN80	DN100	DN125	DN150
	Seal kit a)	HNBR	5629 080 729-020	5629 100 729-020	5629 125 729-020	5629 150 729-020
	Seal kit b)	HNBR	5629 080 729-000	5629 100 729-000	5629 125 729-000	5629 150 729-000
D1	Shaft seal	HNBR	5622 080 010-050	5622 100 010-050	5622 125 010-050	-
D2	O-ring (2x)	HNBR	2304 098 035-050	2304 117 035-050	2304 142 035-050	-
D3	O-ring	EPDM	2304 042 020-170	2304 036 020-170	2304 036 020-170	-
D4	a) Seal (2x)	HNBR	5621 080 025-171	5621 100 025-171	5621 125 025-171	-
	- Jacket	HNBR	5621 080 026-171	5621 100 026-171	5621 125 026-171	-
	- Support ring	AISI303	5621 080 027-020	5621 100 027-020	5621 125 027-020	-
	b) Seal (2x)	HNBR	5621 080 010-157	5621 100 010-157	2304 113 053-157	-
D5	O-ring	HNBR	2304 066 035-157	2304 085 035-157	2304 111 035-157	-
D6	O-ring	EPDM	2304 012 030-050	2304 012 030-050	2304 012 030-050	-
D7	O-ring	HNBR	2304 127 050-171	2304 158 035-050	2304 164 053-050	-
D8	O-ring	EPDM	2304 041 035-159	2304 041 035-159	2304 041 035-157	-
D9	O-ring	EPDM	2304 069 035-159	2304 092 035-159	2304 117 035-159	-
D10	O-ring	NBR	2304 046 025-055	2304 046 025-055	2304 046 025-055	-

**Seal kit FKM**

No.	Designation	Material	DN25	DN40	DN50	DN65
	Seal kit	FKM	5629 025 749-000	5629 040 749-000	5629 050 749-000	5629 065 749-000
D1	Shaft seal	FKM	-	-	-	-
D2	O-ring (2x)	FKM	-	-	-	-
D3	O-ring	FKM	-	-	-	-
D4	Seal (2x)	FKM	-	-	-	-
D5	O-ring	FKM	-	-	-	-
D6	O-ring	FKM	-	-	-	-
D7	O-ring	FKM	-	-	-	-
D8	O-ring	FKM	-	-	-	-
D9	O-ring	FKM	-	-	-	-
D10	O-ring	NBR	-	-	-	-

No.	Designation	Material	DN80	DN100	DN125	DN150
	Seal kit	FKM	5629 080 749-000	5629 100 749-000	5629 125 749-000	5629 150 749-000
D1	Shaft seal	FKM	-	-	-	-
D2	O-ring (2x)	FKM	-	-	-	-
D3	O-ring	FKM	-	-	-	-
D4	Seal (2x)	FKM	-	-	-	-
D5	O-ring	FKM	-	-	-	-
D6	O-ring	FKM	-	-	-	-
D7	O-ring	FKM	-	-	-	-
D8	O-ring	FKM	-	-	-	-
D9	O-ring	FKM	-	-	-	-
D10	O-ring	NBR	-	-	-	-

# 11 Classification

## 11.1 Structure of Order Number

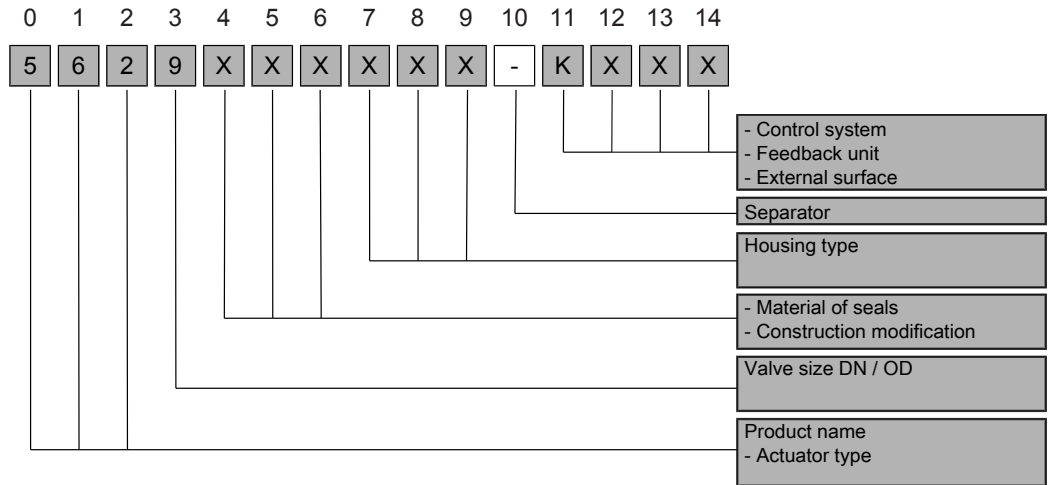

### Product name

<b>5629</b> xxx xxx-xxxx	<b>Pos. 0</b>	<b>Pos. 1</b>	<b>Pos. 2</b>	<b>Pos. 3</b>
Double seat valve Standard	5	6	2	9

### Valve size

xxxx <b>XXX</b> xxx-xxxx							
<b>Nominal diameter</b>	<b>Pos. 4</b>	<b>Pos. 5</b>	<b>Pos. 6</b>	<b>Nominal diameter</b>	<b>Pos. 4</b>	<b>Pos. 5</b>	<b>Pos. 6</b>
DN 25	0	2	5	DN 80	0	8	0
DN 40	0	4	0	DN 100	1	0	0
DN 50	0	5	0	DN 125	1	2	5
DN 65	0	6	5	DN 150	1	5	0
OD 1"	0	2	6	OD 3"	0	7	6
OD 1 1/2"	0	3	8	OD 4"	1	0	1
OD 2"	0	5	1	OD 5"	1	2	7
OD 2 1/2"	0	6	4	OD 6"	1	5	2

### Material of seal / Design modification

xxxx xxx <b>XX</b> x-xxxx		
- Sealing material - in product contact	<b>Pos. 7</b>	<b>Pos. 8</b>
- Design modification		
HNBR [DN25 - DN65; DN100 - DN150]	7	2
HNBR [DN80]	7	0
EPDM [DN25 - DN65; DN100 - DN150]	7	3
EPDM [DN80]	7	1
FKM	7	4

### Housing type

xxxx xxx xx <b>X</b> -xxxx	<b>Pos. 9</b>
Housing S	0
Housing SS	2

**Separator**

xxxx xxx xxx - xxxx	Pos. 10
- Standard	-

**Control system, position indicator, surfaces**

xxxx xxx xxx-XXXX	Pos.11	Pos.12	Pos.13	Pos.14
Valve without control system, External surface AISI304 E-polished	0	2	1	
Valve without control system, External surface AISI316L E-polished	0	4	1	
Valve with feedback (5630 005 025-000)	7	5	0	
Valve with control head, KI-Top SPS for double seat valves	K	5	X	X
Valve with control head, KI-Top ASi-Bus for double seat valves	K	6	X	X



## 12 Appendix

### 12.1 Declaration of incorporation



#### Declaration of incorporation

Translation of the original

#### Manufacturer / authorised representative:

**KIESELMANN GmbH**

Paul-Kieselmann-Str. 4-10

75438 Knittlingen

Germany

#### Authorised representative:

(for compiling technical documents)

**Achim Kauselmann**

(Documentation / Development)

KIESELMANN GmbH

Paul-Kieselmann-Str. 4-10

75438 Knittlingen

Germany

<u>Product name</u>	<u>Function</u>
pneum. Lift actuators	Stroke movement
pneum. Rotary actuators	Rotary movement
Ball valves	Media cutoff
Butterfly valves	Media cutoff
Single seat valves	Media cutoff
Flow control valves	Control of liquefied media
Throttle valve	Control of liquefied media
Overflow valve	Definition of fluid pressure
Double seat valve	Media separation
Bellow valves	Sampling of liquids
Sampling valves	Sampling of liquids
Two way valves	Media cutoff
Tankdome fitting	Prevention of overpressure and vacuum, Tank cleaning
Safety valve	Prevention of overpressure

The manufacturer hereby states that the above product is considered as an incomplete machine in the sense defined in the Directive 2006/42/EC on Machinery. The above product is exclusively intended to be installed into a machine or an incomplete machine. The said product does not yet conform to all the relevant requirements defined in the Directive on Machinery referred to above for this reason.

The specific technical documents listed in Appendix VII, Part B, have been prepared. The Authorized Agent empowered to compile technical documents may submit the relevant documents if such a request has been properly justified.

Commissioning of an incomplete machine must not only be carried out if it has been determined that the respective machine into which the incomplete machine is to be installed conforms to the regulations set out in the Directive on Machinery referred to above.

The above product conforms to the requirements of the directives and harmonized standards specified below:

- Directive 2014/68/EU
- EN ISO 12100 Safety of machinery

Knittlingen, 21.09.2017

i.V. Uwe Heisswolf  
Head of Development

