



# KIESELMANN

FLUID PROCESS GROUP

Translation of the original

## Operating Instructions

### Straight-way ball valve

industrial design

pneumatic und manual operation

Types 406x

416x

426x



**KIESELMANN GmbH**

Paul-Kieselmann-Str. 4-10  
D - 75438 Knittlingen

 +49(0) 7043 371-0 •  +49(0) 7043 371-125  
[www.kieselmann.de](http://www.kieselmann.de) • [info@kieselmann.de](mailto:info@kieselmann.de)

---

Copyright: © KIESELMANN FLUID PROCESS GROUP

## Table of contents

<b>1</b>	<b>General informations</b>	<b>4</b>
1.1	Informations for your safety	4
1.2	Marking of security instructions	4
1.3	General designated use	4
1.4	Personnel	4
1.5	Modifications, spare parts, accessories	5
1.6	General instructions	5
<b>2</b>	<b>Safety instructions</b>	<b>6</b>
2.1	Intended use	6
2.2	General notes	6
2.3	General safety instructions	6
<b>3</b>	<b>Delivery, transport and storage</b>	<b>8</b>
3.1	Delivery	8
3.2	Transport	8
3.3	Storage	8
<b>4</b>	<b>Specification</b>	<b>9</b>
4.1	Modular system	9
<b>5</b>	<b>Function and operation</b>	<b>10</b>
5.1	Description of function	10
5.2	Control system and position indication	11
<b>6</b>	<b>Commissioning, service and maintenance</b>	<b>12</b>
6.1	Commissioning	12
6.1.1	Installation instructions	12
6.1.2	General welding guidelines	12
6.1.3	Use in EX area	12
6.2	Service	13
6.3	Cleaning	13
<b>7</b>	<b>Technical data</b>	<b>14</b>
<b>8</b>	<b>Disassembly and assembly</b>	<b>15</b>
8.1	Disassembly	15
8.2	Assembly	15
<b>9</b>	<b>Drawings and dimensions</b>	<b>16</b>
9.1	Control units	16
9.2	Drawings	17
9.3	Dimensions	18
<b>10</b>	<b>Appendix</b>	<b>19</b>
10.1	Declaration of incorporation	19

# 1 General informations

## 1.1 Informations for your safety

We are pleased that you have decided for a high-class KIESELMANN product. With correct application and adequate maintenance, our products provide long time and reliable operation.





Before installation and initiation, please carefully read this instruction manual and the security advices contained in it. This guarantees reliable and safe operation of this product and your plant respectively. Please note that an incorrect application of the process components may lead to great material damages and personal injury.

In case of damages caused by non observance of this instruction manual, incorrect initiation, handling or external interference, guarantee and warranty will lapse!

Our products are produced, mounted and tested with high diligence. However, if there is still a reason for complaint, we will naturally try to give you entire satisfaction within the scope of our warranty. We will be at your disposal also after expiration of the warranty. In addition, you will also find all necessary instructions and spare part data for maintenance in this instruction manual. If you don't want to carry out the maintenance by yourself, our KIESELMANN - service team will naturally be at your disposal.

## 1.2 Marking of security instructions

Hints are available in the chapter "safety instructions" or directly before the respective operation instruction. The hints are highlighted with a danger symbol and a signal word. Texts beside these symbols have to be read and adhered to by all means. Please continue with the text and with the handling at the valve only afterwards.

Symbol	Signal word	Meaning
	DANGER	Imminent danger which will result severe personal injury or death.
	WARNING	Imminent danger which may result severe personal injury or death.
	CAUTION	Dangerous situation which may cause slight personal injury or material damages.
	NOTICE	An harmful situation which may result in damages of the product itself or of adjacent vicinity.
	INFORMATION	Marks application hints and other information which is particularly useful.

## 1.3 General designated use

The fitting is designed exclusively for the purposes described below. Using the fitting for purposes other than those mentioned is considered contrary to its designated use. KIESELMANN cannot be held liable for any damage resulting from such use. The risk of such misuse lies entirely with the user. The prerequisite for the reliable and safe operation of the fitting is proper transportation and storage as well as competent installation and assembly. Operating the fitting within the limits of its designated use also involves observing the operating, inspection and maintenance instructions.

## 1.4 Personnel

Personnel entrusted with the operation and maintenance of the tank safety system must have the suitable qualification to carry out their tasks. They must be informed about possible dangers and must understand and observe the safety instructions given in the relevant manual. Only allow qualified personnel to make electrical connections.

## **1.5 Modifications, spare parts, accessories**

Unauthorized modifications, additions or conversions which affect the safety of the fitting are not permitted. Safety devices must not be bypassed, removed or made inactive. Only use original spare parts and accessories recommended by the manufacturer.

## **1.6 General instructions**

The user is obliged to operate the fitting only when it is in good working order. In addition to the instructions given in the operating manual, please observe the relevant accident prevention regulations, generally accepted safety regulations, regulations effective in the country of installation, working and safety instructions effective in the user's plant.

## 2 Safety instructions

### 2.1 Intended use

Straight-way ball valves are used as a shut-off valve in units of the beverage and food industry, the pharmacy, the biotechnology as well as the chemical industry.

### 2.2 General notes



#### NOTICE - observe the operating instructions

To avoid danger and damage, the fitting must be used in accordance with the safety instructions and technical data contained in the operating instructions.



#### NOTICE

All data are in line with the current state of development. Subject to change as a result of technical progress.

### 2.3 General safety instructions



#### ⚠ WARNING

##### Risk of injury by outflowing medium

Dismantling the valve or valve assemblies from the plant can cause injuries.

- Medias flowing through the leakage drain outlet are to be drained off without splashing into a discharge arrangement.
- Carry the disassembling only if when the plant has been rendered pressure-less and free of liquid and gas.



#### ⚠ WARNING

##### Risk of injury by moving parts

Do not grab into the valve when the actuator is pressurized. Limbs can be crushing or amputating.

- Remove the control air line before dismantling.
- Ensure that the actuator is unpressurized.



#### ⚠ WARNING

##### Risk of injury by pre-stressed pressure spring.

The pneumatic-mechanical actuator is spring-loaded. When disassembling the actuator, components that jump out may cause injuries.

- Multiturn actuator are maintenance-free and therefore do not need to be opened!



#### ⚠ WARNING

##### ATEX - Guidelines

If the valve or the plant is operated in a potentially explosive atmosphere, the valid ATEX directive of the EC and the installation instructions in this operating manual must be observed.



#### ⚠ CAUTION

To avoid air leaking, only use pneumatic connection parts that have an O-ring seal facing the even surface.



#### ⚠ CAUTION

Before starting the system, the entire pipeline system must be thoroughly cleaned.



 **CAUTION**

Steps should be taken to ensure that no external forces are exerted on the fitting.

## 3 Delivery, transport and storage

### 3.1 Delivery

- Immediately after receipt check the delivery for completeness and transport damages.
- Remove the packaging from the product.
- Retain packaging material, or expose of according to local regulations.

### 3.2 Transport



#### ⚠ CAUTION

##### **Risk of injury and damage to the product**

During the transport the generally acknowledged rules of technology, the national accident prevention regulations and company internal work and safety regulations must be observed.

### 3.3 Storage



#### NOTICE

##### **Damage to the product due to improper storage!**

Observe storage instructions  
avoid a prolonged storage



#### INFORMATION

##### **Recommendation for longer storage**











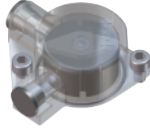

We recommend regularly checking the product and the prevailing storage conditions during long storage times.

- To avoid damage to seals and bearings,
  - products up to DN 125 / OD 5 inch should be stored horizontally for maximum 6 months.
  - products larger than DN 125 / 5 inch, should be stored in the upright position with the actuator on top.
- Don't store any objects on the products.
- Protect the products for wetness, dust and dirt.
- The product should be stored in a dry and well ventilated room at a constant temperature (optimal indoor temperature: 25 C ±5 ; indoor humidity data 70% ±5%).
- Protect seals, bearings and plastic parts for UV light and ozone.

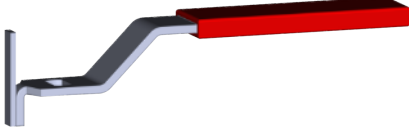
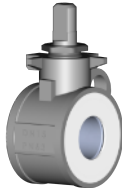
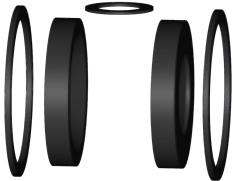

## 4 Specification

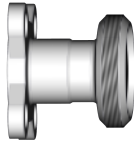
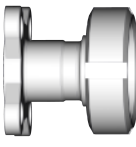
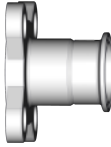
### 4.1 Modular system

KI-Top control head		Feedback unit			
					
Stainless steel hood:	Transparent hood				
drive systems					
pneumatical			electrical		
PDA 90/75 Ø 75	PDA 90/100 Ø 100	PDA 90/125 Ø 125	4040		
					
manual					
Hand lever		Hand lever with sensor mounting			
					
Valve insert					
					
Seal material					
			PTFE		
Connection flanges					
S	G	K/M	CI	FI	Ri
					

## 5 Function and operation

### 5.1 Description of function

Open or close the valve by turning the pneum. controlled rotary drive by 90°.

#### Functional description for valves with manual operation

The manually operated lever is positioned at an angle of 90° in transverse direction to the conduit axis in closed position. The lever is positioned in the direction of the conduit axis in open position.

The possible assembly-line ways in dependence of the stop functions linked with it are shown in the table as valve positions.

#### Valve positions

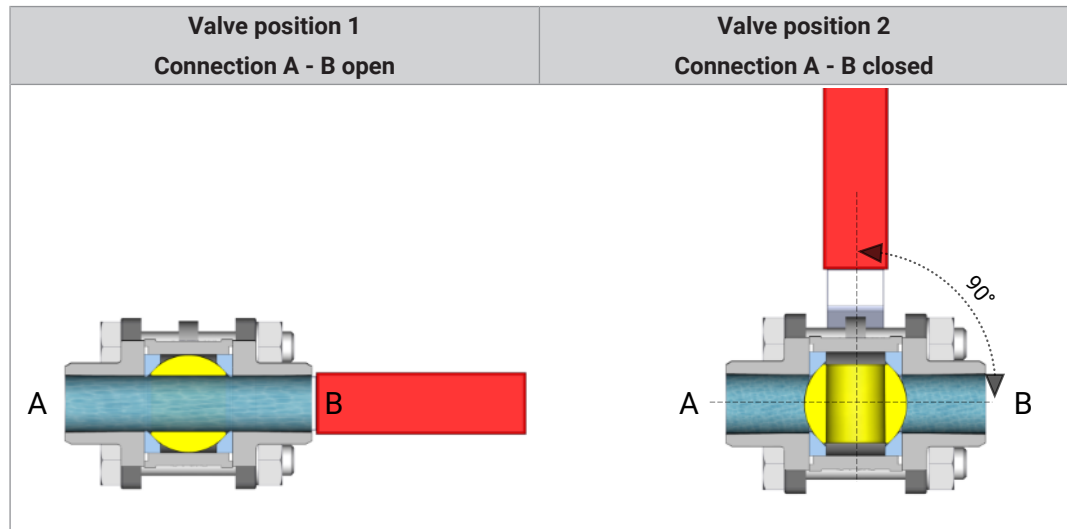

#### Functional description for valves with pneumatic operation

The valve opens and closes by way of a pneum. multiturn actuator with a rotary movement of 90°.

**normal closed (NC)**

- pneum. OPERATED                      opens the valve
- not pneum. OPERATED                spring force closes the valve

**normal open (NO)**

- pneum. OPERATED                      closes the valve
- not pneum. OPERATED                spring force opens the valve

**double acting (DA)**

- pneum. OPERATED                      the valve opens or closes according to control

## 5.2 Control system and position indication

### Retrofitting to end position feedback for manually operated valves

By replacing the hand lever and the catch disc the valve can be retrofitted for end position feedback (proximity switch).

### Conversion from manual operation to pneumatic actuation

By a simple retrofitting operation the valve can be converted to pneumatic actuation. The rotary actuator for this purpose is supplied complete with fitting device. The following actuators are available, depending on the desired actuating function.

Nominal size	Drive	Normally closed (NC)
DN 10   OD ¼"	PDA 90/75	4262 010 010-022
DN 15   OD ½"		4262 015 010-022
DN 20   OD ¾"	PDA 90/100	4262 020 010-022
DN 25   OD 1"		4262 025 010-022
DN 32   OD 1 ¼"		4262 032 010-022
DN 40   OD 1 ½"	PDA 90/125	4262 040 010-022
DN 50   OD 2"		4262 050 010-022

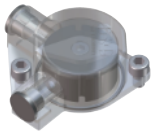

### Position indicator with sensor mounting for feedback signal.

The actuator is equipped with a proximity switch mounting (sensor mounting) and a position indication. When inductive proximity initiators M 12x1 are installed, the current "Open" or "Shut" position can be interrogated. By screwing the proximity initiator to the limit position the required switching gap for the signal transmission is established.. When the valve is closed the position indication is oriented vertically to the direction of valve passage. When the valve is open it is oriented parallel to the valve passage.



### Feedback unit -optional-

Optionally, modular valve control head systems can be installed to the actuator for reading and actuating valve positions. The standard version is a closed system with SPS or ASI-bus switch-on electronics, and integrated 3/2-way solenoid valves. For tough operating conditions we recommend employing a high-grade steel cover.

## 6 Commissioning, service and maintenance

### 6.1 Commissioning

#### 6.1.1 Installation instructions

For ball valves without leakage outlet, the installation position is without importance.

Ball valves with leakage outlet must always be installed vertically to ensure that outflow of leakage, or of cleaning medium, from the valve is such that no residue will remain inside the valve.

For valves which are to be welded in on both sides, a releasable connection has to be fitted into the pipework to allow dismounting (maintenance).

#### 6.1.2 General welding guidelines

Sealing elements integrated in weld components must generally be removed prior to welding. To prevent damage, welding should be undertaken by certified personnel (EN ISO 9606-1). Use the TIG (Tungsten Inert Gas) welding process.



#### CAUTION

##### **Damage and injuries due to high temperature supply**

To avoid a distortion of the components, all welding parts must be welded to stress-relieved.

Allow all components to cool before assembling.



#### NOTICE

##### **Damage due to impurities**

Impurities can cause damage to the seals and seals area.

Clean inside areas prior to assembly.

#### 6.1.3 Use in EX area

For valves or plants/installations that are operated in the ATEX area, sufficient bonding (grounding) must be ensured. (see e.g. ATEX Directives EC; UKSI 696:2019-Schedule 25)

## 6.2 Service



### RECOMMENDATION

#### Replacement of seals

To achieve optimal maintenance cycles, the following points must be observed!

- When replacement of seals, all product-contacting seals should be replaced.
- Only original spare parts may be installed.

#### Maintenance interval

The maintenance intervals depend on the operating conditions "temperature, temperature-intervals, medium, cleaning medium, pressure and opening frequency". We recommend replacing the seals 2-year cycle. The user, however should establish appropriate maintenance intervals according to the condition of the seals.

#### Lubricant recommendation

	EPDM; HNBR; NBR; FKM; k-flex	- Klüber Paraliq GTE703*
	Silicone	- Klüber Sintheso pro AA2*
	Thread	- Interflon Food*
*) It is only permitted to use approved lubricants, if the respective fitting is used for the production of food or drink. Please observe the relevant safety data sheets of the manufacturers of lubricants.		

## 6.3 Cleaning

In order to ensure continuous flawless function during operation, the surfaces between the valve body and the ball must be cleaned.

Open and close the valve several times from the open position. With an angle of rotation of  $\geq 20^\circ$ , cleaning fluid flows into the area between the ball and casing. A time-dependent actuation in the angle of rotation range  $20^\circ$ - $45^\circ$  makes the cleaning process more efficient. The duration and the number of actuations should be adjusted according to the type of dirtying and the degree of dirtying.

## 7 Technical data

Model:	Straight-way ball valve	
Valve size:	Valves - manual operation DIN: DN 10 - DN 100 Inch: DN ¼" - DN 2"	
	Valve - pneumatical DIN: DN 10 - DN 50 Inch: DN ¼" - DN 2"	
Connections:	Welded end (S) DIN EN 10357 Thread (G) DIN 11851 Liner/nut (K/M) DIN11581 Clamp connection (Cl) Flange connection (Fl) Pipe Thread (Ri)	
Temperature range:	Ambient (air)	+4° to +45°C
	Operating (medium dependent)	+0° to +95°C
	Sterilization (SIP 30 min)	PTFE +140°C
Pressure range:	Operating pressure:	56 bar (at 20°C)
Leak rate:	A (DIN EN 12266-1)	
Control air:	<u>Control air pressure:</u> 5,5 - 8,0 bar	<u>Quality of control air:</u> ISO 8573-1 : 2001 quality class 3
Materials: (in product contact)	Stainless steel:	1.4301 / AISI304 1.4404 / AISI316L 1.4408 / AISICF-8M / SCS14
	Surfaces:	Ra < 0,8µm e-polished
	Sealing material:	PTFE

## 8 Disassembly and assembly

### 8.1 Disassembly



#### NOTICE

All threaded joint have right-hand thread.

Unscrew and remove control air, steam resp. cleaning lines and electrical lines, complete feedback unit or control head.

#### Ball valve - pneum. operation - dismount actuator

- Unscrew the nuts (17a) and remove screws (15a).
- Remove the complete actuator (22).
- Remove the square boss (19).

#### Ball valve manual operation - Dismount hand lever

- Unscrew the screw (8).
- Remove the disc (9) and hand lever (3).

#### Replacement wear parts

- Unscrew the nuts (17b) and remove screws (15b).
- Remove flanges (2).
- Dismantle the O-rings (14) and thrust collar (6).
- Dismount the ball (7) from the housing (1).
- Remove axle (5).
- Dismount the sealing package (10,11,12,13) from the housing (1).

### 8.2 Assembly

- Before installation, thoroughly clean and slightly lubricate mounting areas and running surfaces.
- Assemble in reverse order.

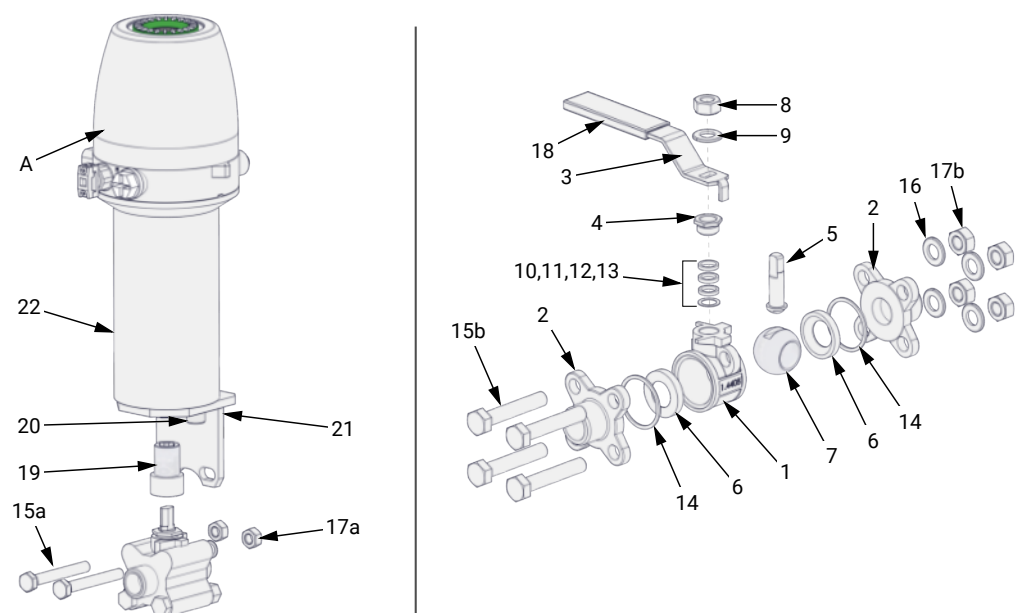

## 9 Drawings and dimensions

### 9.1 Control units

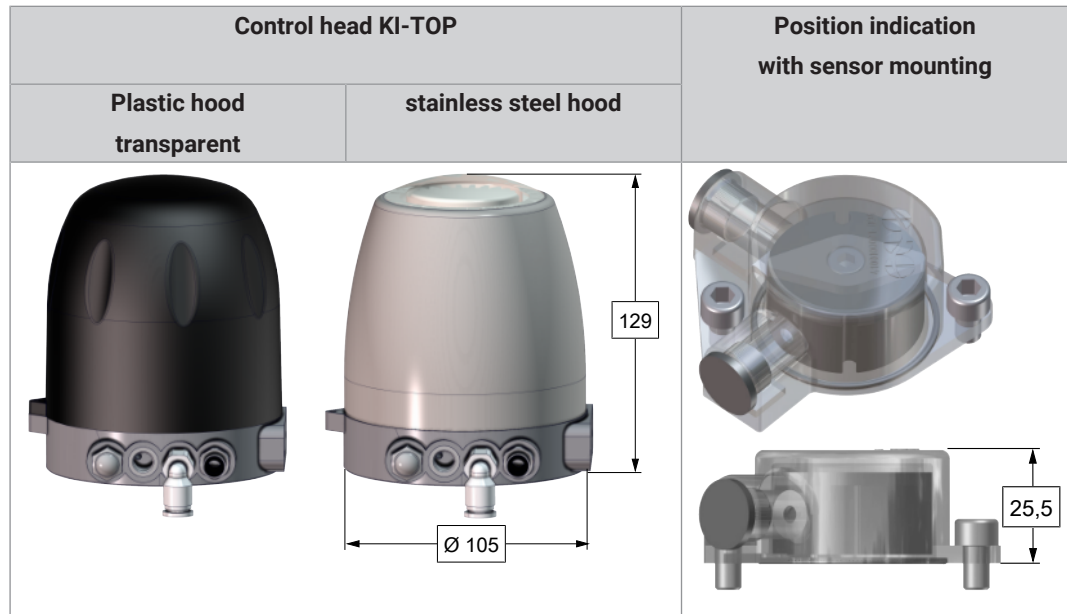

#### Position indication with sensor mounting (R)

- R1 = dog
- R1.1 = Straight pin
- R2 = Position indication
- R3 = O-ring
- R4 = Screw
- R5 = Sensor mounting
- R6 = Cap
- R7 = Screw
- LA = air supply

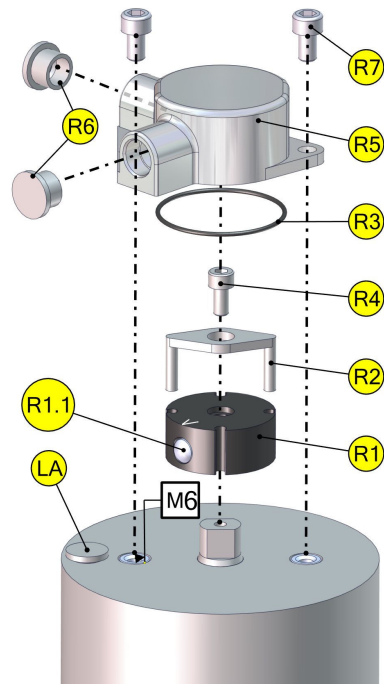



### 9.2 Drawings

- 1 = Housing
  - 2 = Flange
  - 3 = Hand lever
  - 4 = Nut
  - 5 = Axis
  - 6 = Thrust collar
  - 7 = Ball
  - 8 = Nut
  - 9 = Disc
  - 10-13 = Sealing package
  - 14 = O-ring
  - 15 = Screw
  - 16 = Disc
  - 17 = Nut
  - 18 = Cap for hand lever
  - 19 = Square boss
  - 20 = Screw
  - 21 = Holding flange
  - 22 = Actuator
- A = Control head

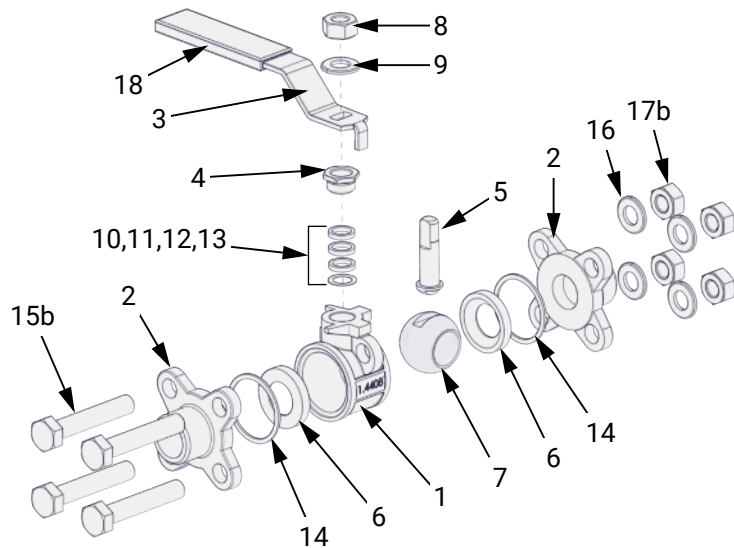
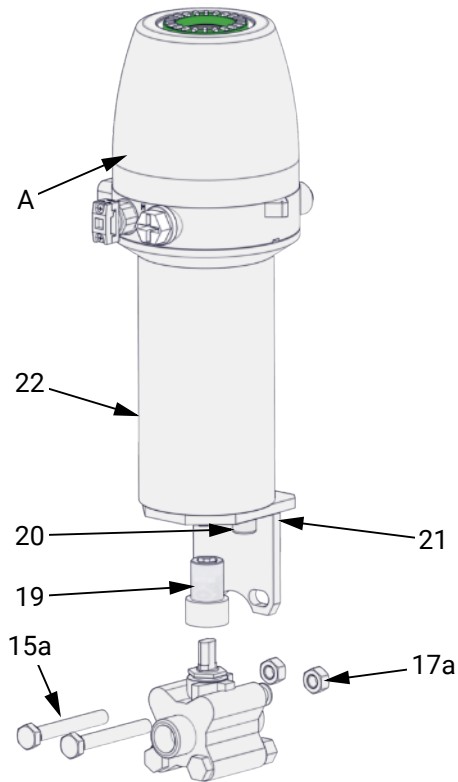

### 9.3 Dimensions

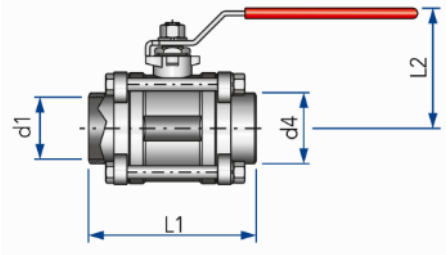
Straight-way ball valve S-S, manual operation		DN	d1	d4	L1	L2
	10	12.5	18.5	63	51	
	15	16.0	21.5	73	60	
	20	20.0	26.0	85	63	
	25	25.0	31.0	94	76	
	32	32.0	38.5	110	81	
	40	38.0	45.0	122	93	
	50	51.0	58.5	142	102	
	65	65.0	75.0	167	132	
	80	80.0	92.5	192	143	
	100	100.0	114	226	174	

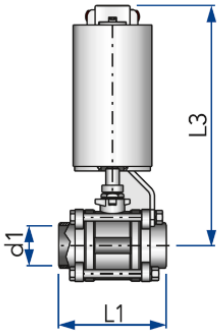
Straight-way ball valve S-S, pneumatic operation		DN	d1	L1	L3
	10	12.5	63	278	
	15	16.0	73	286	
	20	20.0	85	289	
	25	25.0	94	291	
	32	32.0	110	302	
	40	38.0	122	335	
	50	51.0	142	345	
	65	-	-	-	
	80	-	-	-	
	100	-	-	-	

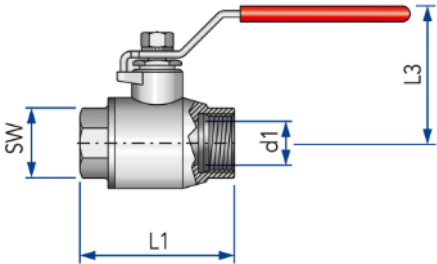
Straight-way ball valve S-S, pneumatic operation		OD	d1	L1	L3	SW
	1/4"	1/4"	54	51	23	
	3/8"	3/8"	54	51	23	
	1/2"	1/2"	64	60	28	
	3/4"	3/4"	76	63	33	
	1"	1"	88	76	40	
	1 1/4"	1 1/4"	88	82	50	
	1 1/2"	1 1/2"	120	93	58	
	2"	2"	134	101	71	

## 10 Appendix

### 10.1 Declaration of incorporation



#### Declaration of incorporation

Translation of the original

#### Manufacturer / authorised representative:

**KIESELMANN GmbH**

Paul-Kieselmann-Str. 4-10

75438 Knittlingen

Germany

#### Authorised representative:

(for compiling technical documents)

**Achim Kauselmann**

(Documentation / Development)

KIESELMANN GmbH

Paul-Kieselmann-Str. 4-10

75438 Knittlingen

Germany

<u>Product name</u>	<u>Function</u>
pneum. Lift actuators	Stroke movement
pneum. Rotary actuators	Rotary movement
Ball valves	Media cutoff
Butterfly valves	Media cutoff
Single seat valves	Media cutoff
Flow control valves	Control of liquefied media
Throttle valve	Control of liquefied media
Overflow valve	Definition of fluid pressure
Double seat valve	Media separation
Bellow valves	Sampling of liquids
Sampling valves	Sampling of liquids
Two way valves	Media cutoff
Tankdome fitting	Prevention of overpressure and vacuum, Tank cleaning
Safety valve	Prevention of overpressure

The manufacturer hereby states that the above product is considered as an incomplete machine in the sense defined in the Directive 2006/42/EC on Machinery. The above product is exclusively intended to be installed into a machine or an incomplete machine. The said product does not yet conform to all the relevant requirements defined in the Directive on Machinery referred to above for this reason.

The specific technical documents listed in Appendix VII, Part B, have been prepared. The Authorized Agent empowered to compile technical documents may submit the relevant documents if such a request has been properly justified.

Commissioning of an incomplete machine must not only be carried out if it has been determined that the respective machine into which the incomplete machine is to be installed conforms to the regulations set out in the Directive on Machinery referred to above.

The above product conforms to the requirements of the directives and harmonized standards specified below:

- Directive 2014/68/EU
- EN ISO 12100 Safety of machinery

Knittlingen, 21.09.2017

i.V. Uwe Heisswolf  
Head of Development

